

INSTALLATION, OPERATING & MAINTENANCE MANUAL

ELECTRIC CHAIN HOIST



CM[®]

SHOPSTAR

Before installing hoist, fill in the information below.

Model Number _____

Serial No. _____

Purchase Date _____

Follow all instructions and warnings for inspecting,



maintaining and operating this hoist.

The use of any hoist presents some risk of personal injury or property damage. That risk is greatly increased if proper instructions and warnings are not followed. Before using this hoist, each operator should become thoroughly familiar with all warnings, instructions and recommendations in this manual. **Retain this manual for future reference and use.**

Forward this manual to the hoist operator. Failure to operate equipment as directed in manual may cause injury.

Columbus McKinnon Corporation
205 Crosspoint Parkway
Getzville, NY 14068

CM HOIST PARTS AND SERVICES ARE AVAILABLE IN THE UNITED STATES AND CANADA

PARTS FOR YOUR HOIST ARE AVAILABLE FROM YOUR LOCAL AUTHORIZED REPAIR STATION. FOR THE NAME OF THE NEAREST PARTS OR SERVICE CENTER, VISIT OUR WEB SITE WWW.CMWORKS.COM OR CALL OUR CUSTOMER SERVICE DEPARTMENT AT 800-888-0985.

AN ELECTRONIC COPY OF THIS MANUAL AND THE CM HOIST PARTS AND SERVICES LIST IS AVAILABLE AT:



<https://www.cmworks.com/Hoists/PoweredHoists/ElectricChainHoist/ShopStar>



Follow all instructions and warning for inspecting, maintaining and operating this hoist.

WARNING

Improper operation of a hoist can create a potentially hazardous situation which, if not avoided, could result in death or serious injury. To avoid such a potentially hazardous situation, THE OPERATOR SHALL:

- a. **NOT** operate a damaged, malfunctioning or unusually performing hoist.
- b. **NOT** operate the hoist until you have thoroughly read and understood this Operating, Maintenance and Parts Manual.
- c. **NOT** operate a hoist which has been modified.
- d. **NOT** lift more than rated load for the hoist.
- e. **NOT** use hoist with twisted, kinked, damaged, or worn load chain.
- f. **NOT** use the hoist to lift, support, or transport people.
- g. **NOT** lift loads over people.
- h. **NOT** operate a hoist unless all persons are and remain clear of the supported load.
- i. **NOT** operate unless load is centered under hoist.
- j. **NOT** attempt to lengthen the load chain or repair damaged load chain.
- k. Protect the hoist's load chain from weld splatter or other damaging contaminants.
- l. **NOT** operate hoist when it is restricted from forming a straight line from hook to hook in the direction of loading.
- m. **NOT** use load chain as a sling, or wrap chain around load.
- n. **NOT** apply the load to the tip of the hook or to the hook latch.
- o. **NOT** apply the load unless load chain is properly seated in the chain wheel(s) or sprocket(s).
- p. **NOT** apply load if bearing prevents equal loading on all load supporting chains.
- q. **NOT** operate beyond the limits of the load chain travel.
- r. **NOT** leave load supported by the hoist unattended unless specific precautions have been taken.
- s. **NOT** allow the load chain or hook to be used as an electrical or welding ground.
- t. **NOT** allow the load chain or hook to be touched by a live welding electrode.
- u. **NOT** remove or obscure the warnings on the hoist.
- v. **NOT** operate a hoist on which the safety placards or decals are missing or illegible.
- w. **NOT** operate a hoist unless it has been securely attached to a suitable support.
- x. **NOT** operate a hoist unless load slings or other approved single attachments are properly sized and seated in the hook saddle.
- y. Take up slack carefully - make sure load is balanced and load holding action is secure before continuing.
- z. Shut down a hoist that malfunctions or performs unusually and report such malfunction.
- aa. Make sure hoist limit switches function properly.
- ab. Warn personnel of an approaching load.

CAUTION

Improper operation of a hoist can create a potentially hazardous situation which, if not avoided, could result in minor or moderate injury. To avoid such a potentially hazardous situation, THE OPERATOR SHALL:

- a. Maintain firm footing or be otherwise secured when operating the hoist.
- b. Check brake function by tensioning the hoist prior to each lift operation.
- c. Use hook latches. Latches are to retain slings, chains, etc. under slack conditions only.
- d. Make sure the hook latches are closed and not supporting any parts of the load.
- e. Make sure the load is free to move and will clear all obstructions.
- f. Avoid swinging the load or hook.
- g. Make sure hook travel is in the same direction as shown on the controls.
- h. Inspect the hoist regularly, replace damaged or worn parts, and keep appropriate records of maintenance.
- i. Use factory parts when repairing the unit.
- j. Lubricate load chain per hoist manufacturer's recommendations.
- k. **NOT** use the hoist's overload limiting clutch to measure load.
- l. **NOT** use limit switches as routine operating stops. They are emergency devices only.
- m. **NOT** allow your attention to be diverted from operating the hoist.
- n. **NOT** allow the hoist to be subjected to sharp contact with other hoists, structures, or objects through misuse.
- o. **NOT** adjust or repair the hoist unless qualified to perform such adjustments or repairs.

SAFETY PRECAUTIONS

Each Shopstar Electric Hoist is built in accordance with the specifications contained herein and at the time of manufacture complied with our interpretation of applicable sections of the National Electrical Code (ANSI/NFPA 70). Installers are required to provide current overload protection and grounding in keeping with the code. Check each installation for compliance with the applicable sections of the code as well as the National, State and Local Codes that may apply to the installation. In addition, safety code requirements associated with the operation of a hoist in the inverted (theatrical) position (chain port up), as with any mechanical equipment, vary depending upon locality. Therefore, before installing the hoist, the user should consult his insurance company and/or local authority to see if a deviation is required to permit the use of the hoist in this particular application.

The safety laws for elevators, lifting of people and for dumbwaiters specify construction details that are not incorporated into the hoists. For such applications, refer to the requirements of applicable state and local codes, and the American National Safety Code for elevators, dumbwaiters, escalators and moving walks (ASME A17.1). We cannot be responsible for applications other than those for which the equipment is intended.

*Copies of this standard can be obtained from ASME Order Department, 22 Law Drive, PO Box 2300, Fairfield, NJ 07007- 2300, U.S.A., www.asme.org, 800-843-2763.



THIS SYMBOL POINTS OUT IMPORTANT SAFETY INSTRUCTIONS WHICH IF NOT FOLLOWED COULD ENDANGER THE PERSONAL SAFETY AND/OR PROPERTY OF YOURSELF AND OTHERS. READ AND FOLLOW ALL INSTRUCTIONS IN THIS MANUAL AND ANY PROVIDED WITH THE EQUIPMENT BEFORE ATTEMPTING TO OPERATE YOUR SHOPSTAR HOIST.

HOIST SAFETY IS UP TO YOU...

⚠ WARNING

DO NOT LIFT MORE THAN RATED LOAD.

CHOOSE THE RIGHT HOIST FOR THE JOB...

Choose a hoist with the capacity for the job. Know the capacities of your hoists and the weight of your loads. Then match them.

The application, the size and type of load, the attachments to be used and the period of use must also be taken into consideration in selecting the right hoist for the job.

Remember, the hoist was designed to ease our burden and carelessness not only endangers the operator, but in many cases, a valuable load.



⚠ WARNING

DO NOT OPERATE DAMAGED OR MALFUNCTIONING HOIST.

DO NOT OPERATE WITH TWISTED, KINKED, OR DAMAGED CHAIN.

INSPECT

All hoists should be visually inspected before use, in addition to regular, periodic maintenance inspections.

Inspect hoists for operations warning notices and legibility.

Deficiencies should be noted and brought to the attention of supervisors. Be sure defective hoists are tagged and taken out of service until repairs are made.

Under no circumstances should you operate a malfunctioning hoist.

Check for gouged, twisted, distorted links and foreign material. Do not operate hoists with twisted, kinked, or damaged chain links.

Load chain should be properly lubricated.

Hooks that are bent, worn, or whose openings are enlarged beyond normal throat opening should not be used. If latch does not engage throat opening of hook, hoist should be taken out of service.

Chains should be checked for deposits of foreign material which may be carried into the hoist mechanism.

Check brake for evidence of slippage under load.



⚠ WARNING

DO NOT PULL AT AN ANGLE. BE SURE HOIST AND LOAD ARE IN A STRAIGHT LINE.

DO NOT USE LOAD CHAIN AS A SLING.

USE HOIST PROPERLY

Be sure hoist is solidly held in the uppermost part of the support hook arc.

Be sure hoist and load are in a straight line. Do not pull at an angle.

Be sure load is hooked securely. Do not tip load the hook. Do not load hook latch. Hook latch is to prevent detachment of load under slack chain conditions only.

Do not use load chain as a sling. Such usage damages the chain and lower hook.

Do not operate with hoist head resting against any object. Lift the load gently. Do not jerk it.

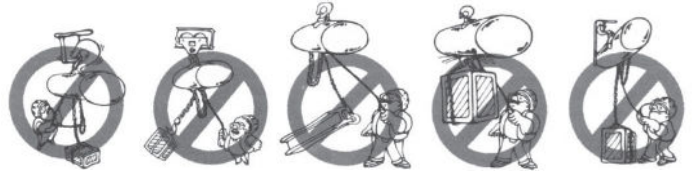

⚠ WARNING

DO NOT LIFT PEOPLE OR LOADS OVER PEOPLE

LIFT PROPERLY

Do not lift co-workers with a hoist.

Make sure everyone is clear of the load when you lift.

Do not remove or obscure operational warning notices.

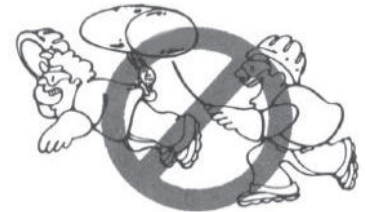

MAINTAIN PROPERLY

CLEANING

Hoists should be kept clean and free of dust, dirt, moisture, etc., which will in any way affect the operation or safety of the equipment.

LUBRICATION

Chain should be properly lubricated.

AFTER REPAIRS

Carefully operate the hoist before returning it to full service.



VIOLATIONS OF ANY OF THE WARNINGS LISTED MAY RESULT IN SERIOUS PERSONAL INJURY TO THE OPERATOR OR NEARBY PERSONNEL BY NATURE OF RELEASED LOAD OR BROKEN HOIST COMPONENTS.

FOREWORD

This manual contains important information to help you properly install, operate and maintain your hoist for maximum performance, economy and safety.

Please study its contents thoroughly before putting your hoist into operation. By practicing correct operating procedures and by carrying out the recommended preventive maintenance suggestions, you will experience long, dependable and safe service. After you have completely familiarized yourself with the contents of this manual, we recommend that you carefully file it for future reference.

The information herein is directed to the proper use, care and maintenance of the hoist and does not comprise a handbook on the broad subject of rigging.

Rigging can be defined as the process of lifting and moving heavy loads using hoists and other mechanical equipment. Skill acquired through specialized experience and study is essential to safe rigging operations. For rigging information, we recommend consulting a standard textbook on the subject.

TABLE OF CONTENTS

Master Parts Depots And Service Centers	2
Safety Precautions	3
Foreword	5

SPECIFICATIONS

Electric Chain Hoists	6
Repair/Replacement Policy	6
Accessories	7

INSTALLATION

Unpacking	8
Mounting the Hoist	8
Power Supply System	8
Three Phase Hoists	9
Checking for Adequate Voltage at Hoist	9

OPERATION

General	10
---------------	----

MAINTENANCE

Inspection	11
Preventive Maintenance	11
Inspection Table	12
Hook Inspection	13
Hook Replacement Criteria	13
Inspecting The Load Chain	13
Lubrication	14
Electric Brake	15

TROUBLESHOOTING

General	16
---------------	----

ELECTRICAL DATA

Open or Short Circuit in Electrical Components	18
--	----

DISASSEMBLY-ASSEMBLY

General	19
Load Chain Removal/Installation	19
Cutting Chain	20
Testing	20

LIST OF TABLES

TABLE	DESCRIPTION	PAGE
1	Specifications	6
2	Nominal Voltage	9
3	Start-up Voltage	9
4a-b	Adequate Power Supply	9
5	Inspection Table	12
6	Electrical Data for Components	18
7	Torque Settings	19

LIST OF ILLUSTRATIONS

FIG.	DESCRIPTION	PAGE
1	Chain Container	7
2	Latchlok Hook	7
3	632 Trolley	7
4	UT Trolley	7
5	CM Rocket Universal Pendant Control	7
6	Single Phase Systems	8
7	Three Phase Systems	8
8	Nameplate	9
9	Hoist Components	9
10	Hook Inspection	13
11	Chain Inspection	14
12	Chain Wear Areas	14
13	Chain Identification	14
14	Brake Field Assembly	15
15	Drive Shaft Assembly	15
16	Brake Assembly	15
17	Main Frame	19
18	Stator Installation	19
19	Chaining Hoist	19
20	Chaining Diagram	20
21	Chain Stop	20
22	Cutting Chain by Nicking	20
23	Cutting Chain with a Bold Cutter	20

SPECIFICATIONS

Standard features of the Electric Chain Hoist include:

- Alloy steel, oblique lay liftwheel that provides constant chain speed and reduces chain wear.
- Hoistaloy® load chain for long and dependable service.
- Grease lubricated, hardened spur gears provide smooth and quiet operation.
- Thermally protected, hoist duty motor.
- Forged steel upper and lower hooks with latch.
- Protector™ that prevents lifting dangerous overloads.
- D.C. disc type motor brake plus regenerative braking.
- 10 foot (3 M) lift. Longer lifts can be supplied on a per order basis.
- 6 foot (1.8 M) power cord with three prong plug for grounding on 115-1-50/60 units. 6 foot (1.8 M) power cord with provisions for grounding is standard on 220-1-50 and three phase units.
- Rugged NEMA 4 (weatherproof) control station is suspended on a TYPE SO cord six feet (2.8 M) below the bottom of the hoist. Longer cords can be provided on a per order basis.
- Lightweight die cast aluminum frames and covers.
- Ball or needle bearings at all rotating points.
- Compact, yet rugged, design provides minimum headroom and long, trouble-free service
- 220-1-50, 380 to 460-3-50/60, 220 to 240-3-50/60 and 575-3-60 units available. Lift speeds are based on 60 hertz power supply. For 50 hertz power supply lift speeds will be 5/6 of those indicated.
- Speeds and capacities based on Table 1, below.
- UL and cUL listed.
- Lifetime Warranty.

Follow all instructions and warnings for inspecting, maintaining and operating this hoist.

The use of any hoist presents some risk of personal injury or property damage. That risk is greatly increased if proper instructions and warnings are not followed. Before using this hoist, each operator should become thoroughly familiar with all warnings, instructions, and recommendations in this manual.

Retain this manual for future reference and use.

Forward this manual to the hoist operator. Failure to operate the equipment as directed in the manual may cause injury. Before putting hoist into service, fill in the information below. Refer to the hoist identification plate.

Model Number _____

Serial No. _____

Purchase Date _____

Voltage _____

Rated Load _____

Table 1 - Specifications

Lift	6 fpm	8 fpm	12 fpm	13.3 fpm	16 fpm	20 fpm	24 fpm	40 fpm
250 lb					x		x	x
300 lb					x	x	x	x
500 lb		x	x		x	x	x	
550 lb				x				
600 lb		x	x					
1000 lb	x	x	x					

REPAIR/REPLACEMENT POLICY

All Electric Chain Hoists are inspected and performance tested prior to shipment. If any properly maintained hoist develops a performance problem, due to a material or workmanship defect, as verified by the factory, repair or replacement of the unit will be made to the original purchaser without charge. This repair/replacement policy applies only to Shopstar Hoists installed, maintained and operated as outlined in this manual, and specifically excludes hoists subject to normal wear, abuse, improper installation, improper or inadequate maintenance, hostile environmental effects and unauthorized repairs/modifications.

We reserve the right to change materials or design if, in our opinion, such changes will improve our product. Abuse, repair by an unauthorized person, or use of non-factory replacement parts voids the guarantee and could lead to dangerous operation. All Shopstar Electric Chain Hoists are backed with a lifetime warranty. Refer to the back cover for details and limitations.

WARNING

Alterations or modification of hoist and use of non-factory repair parts can lead to dangerous operation and injury.

TO AVOID INJURY:

- Do not alter or modify equipment.
- Do use only factory replacement parts.



Figure 1 - Chain Container



Figure 2 - Latchlok Hook



Figure 3 - 632 Trolley



Figure 4 - UT Trolley



Figure 5 - CM® Rocket™ Universal Pendant Control

ACCESSORIES

HOOK SUSPENSIONS

Swivel and rigid type hook suspensions are available for all Shopstar Electric Hoists. However, swivel type hook suspensions are normally recommended for most applications.

CHAIN CONTAINER

This accessory item (Figure 1) is used to hold the slack chain and it is supplied with mounting hardware and instructions. Chain containers are recommended for those applications where slack chain will interfere with the load or drag on the floor as may more often be the case with the double-reeved units (500, 600, 1,000lb - 226, 272, and 453kg). Chain containers are shipped separately and can be furnished for units already in service.

LATCHLOK®HOOKS

CM's Latchlok hooks are available (Figure 2) to replace the standard upper and lower hooks used on the Shopstar Electric Hoists.

CM SERIES 632 TROLLEY

This lightweight, yet, rugged, manual push type trolley (Figure 3) is designed to fit a wide range of monorail beams and negotiate tight curves. Provides mobility of your hoist.

CM UNIVERSAL (UT) TROLLEY

The CM Universal Trolley (UT) is designed to fit virtually all Columbus McKinnon powered chain hoists up to 3 ton capacities. The rugged UT is available as a convertible plain unit, a geared unit ideal for precise hoist positioning, and a motorized unit that's perfect for applications requiring high cycling and long distance hoist travel.

CM® ROCKET™ UNIVERSAL PENDANT CONTROL

The CM Rocket Pendant Control is engineered for maximum operator comfort, while delivering the precision control your application demands.

INSTALLATION

UNPACKING

After opening the carton, carefully inspect the hoist frame, cords, hooks, chain and control station for damage that may have occurred during shipment. If there is damage, refer to the packing slip envelope.

Make sure that the power supply to which the hoist is to be connected is the same as that shown on the identification plate located on bottom of hoist.

⚠ WARNING
Operating a unit with obvious external damage may cause load to drop and that may result in personal injury and/or property damage.
TO AVOID INJURY:
Carefully check unit for external damage prior to installation.

MOUNTING THE HOIST

Hang the hoist from its intended support. The structure used to support the hoist must have sufficient strength to withstand several times the load imposed. If in doubt consult a registered engineer and local building codes.

⚠ WARNING
Suspending the hoist from an inadequate support may allow the hoist and load to fall and cause injury and/or property damage.
TO AVOID INJURY:
Make sure the attachment point has sufficient strength to hold several times the hoist and its rated load. Using the upper hook, hang the hoist from the support. Be sure hoist is solidly held in the uppermost part of the hook arc and the latch is tightly against the hook tip.

POWER SUPPLY SYSTEM

(Refer to Figure 6 or 7). To insure proper operation, to avoid damage to hoist and electrical system and to reduce the risk of electric shock or fire, the branch circuit supplying power to the hoist must:

1. Have ample capacity to prevent excessive voltage drop during starting and operation (refer to Figure 8). When determining the size of branch circuit components and conductors, special consideration should be given to the starting current-amps (approximately three times that shown on the hoist identification plate) and the length of the conductors. As a minimum, the system should be rated for 15 amps and it should have #16 AWG, or larger, wiring.
2. Be in accordance with the National Electrical Code (ANSI/NFPA-70) and applicable National, State and Local Codes.
3. Effectively ground the hoist in accordance with National Electrical Code and other applicable codes. Proper grounding provides a path of least resistance for electric current to reduce the risk of electric shock. The power cord of the hoist includes a green-yellow wire for grounding the hoist to the external power supply system. Be sure that the receptacle opening that receives the longest prong is properly grounded. If grounding is to be through the trolley trackwheels, each section of the runway must be grounded to the building ground system using metal to metal connections.
4. Include slow blow type fuses or inverse trip time circuit breakers to permit the hoist to start and accelerate load.
5. Include a disconnecting means capable of being locked in the "open" position.

⚠ WARNING
Failure to properly ground the hoist presents the danger of electric shock.
TO AVOID INJURY:
Permanently ground the hoist as instructed in this manual.

⚠ CAUTION
To reduce the risk of electric shock or injury, use indoors only.

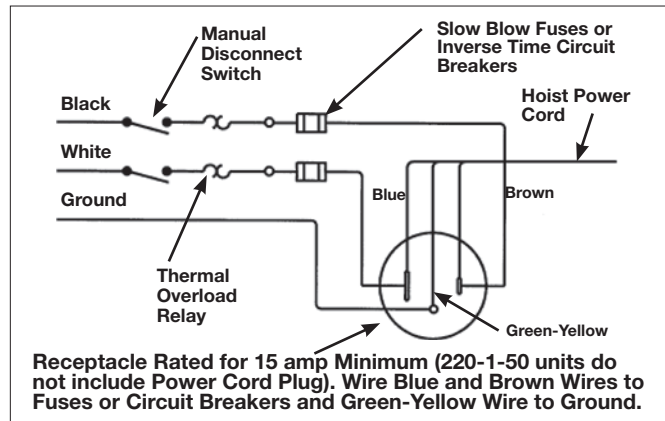

Figure 6 - Single Phase Systems

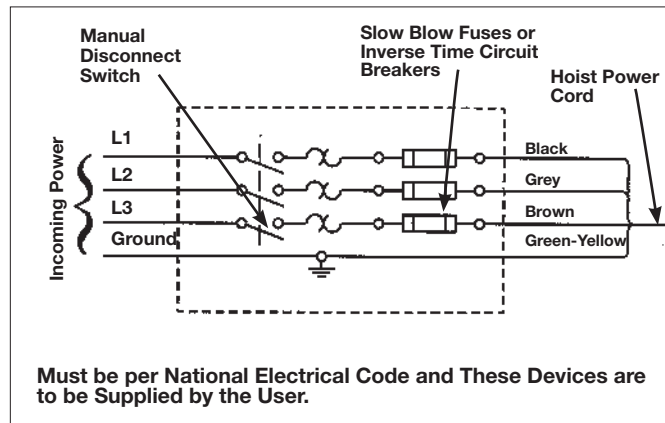

Figure 7 - Three Phase Systems

⚠ WARNING
Failure to provide a proper power supply system for the hoist may cause hoist damage and offers the potential for a fire.
TO AVOID INJURY:
Provide the hoist with a 15 amp, minimum, overcurrent protected power supply per the National Electrical Code (ANSI/NFPA 70) and applicable local codes as instructed in this manual.

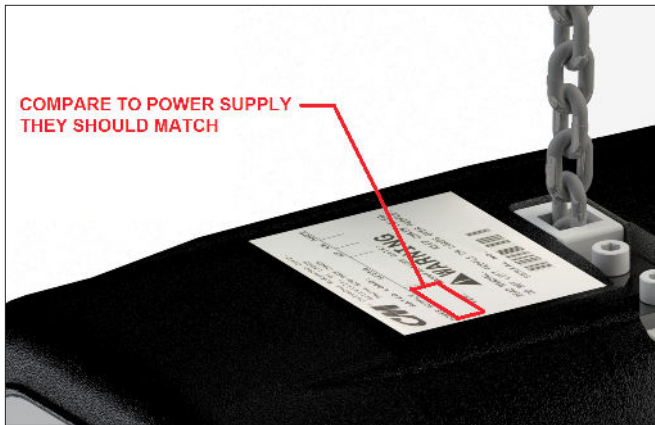

Figure 8 - Nameplate

Note
In this manual, nominal voltages are used when referring to power supply systems. However, with no modification, the Shopstar Hoist will operate on a range of voltages as indicated below:

Table 2 - Nominal Voltage

NOMINAL VOLTAGE	VOLTAGE RANGE	HERTZ	TRADITIONAL CONTACTOR	PRINTED CIRCUIT BOARD
230	208-240	60	AVAILABLE	AVAILABLE
460	440-480	60	AVAILABLE	NOT AVAILABLE
220	200-240	50	AVAILABLE	AVAILABLE
380	365-395	50	AVAILABLE	AVAILABLE
415	400-415	50	AVAILABLE	AVAILABLE
430	415-430	50	AVAILABLE	NOT AVAILABLE
575	550-600	60	AVAILABLE	NOT AVAILABLE

THREE PHASE HOISTS

Since the motor in a three phase hoist can rotate in either direction, depending on the manner in which it is connected to the power supply, the direction of hook movement must be checked during the original installation and each time hoist is moved to a new location as follows:

1. Move the manual disconnect switch handle to the "OFF" position.
2. Connect the BROWN, GREY AND BLACK wires of hoist power cord to load side of disconnect switch. Connect the GREEN-YELLOW wire of hoist power cord to power supply ground.
3. Move the manual disconnect switch handle to the "ON" position.
4. Depress the (up) control. If the hook moves in the up direction, the hoist is ready for operation. If the hook lowers, move the disconnect switch handle to the "OFF" position and interchange the BLACK and BROWN leads at the disconnect switch. Move the disconnect switch handle to the "ON" position and the hoist is now ready for operation.

CHECKING FOR ADEQUATE VOLTAGE AT HOIST

The hoist must be supplied with adequate electrical power for proper operation and to reduce problems that may result from insufficient power (low voltage). These include:

- Noisy hoist operation due to brake and/or contactor chatter.
- Heating of the hoist motor and other internal components as well as heating of wires and connectors in the circuit feeding the hoist.
- Failure of the hoist to lift the load due to motor stalling.
- Blowing fuses or tripping circuit breakers.
- Dimming of lights or slowing of motors connected to the same circuit.

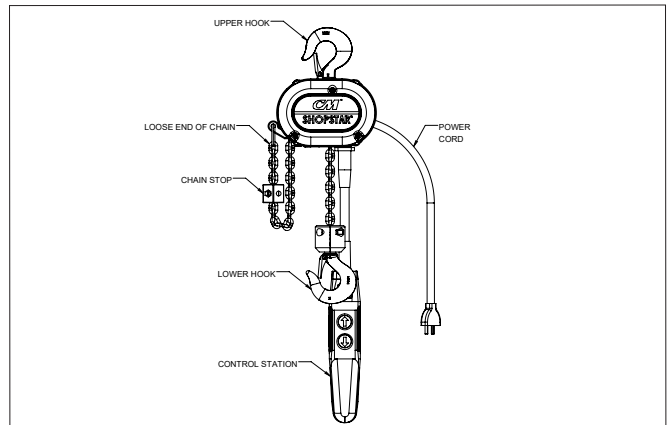

Figure 9 - Hoist Components

For proper operation and to avoid these low voltage problems, voltage (measured at end of the power cord while lifting rated load) should be as the following chart indicates.

Table 3 - Start-up Voltage

NOMINAL MINIMUM * MIN. VOLTAGE POWER OPERATING AT INSTANT SUPPLY VOLTAGE OF START	
115-1-50/60	108
220-1-50	198
208-3-60	187
220-3-50	198
230-3-60	207
380-3-50	365
415-3-50	399
460-3-60	414
575-3-60	518

*The drop in voltage upon energizing the hoist should not be below the value listed.

Low voltage can also be caused by using an undersize extension cord to supply power to the hoist. The following charts should be used to determine the size wires in the extension cord in order to minimize the voltage drop between the power source and the hoist.

115-1-50/60 units with contactor, 220-1-50 units and three phase units (hoists with black control station)

Table 4a - Adequate Power Supply

MAXIMUM LENGTH OF EXTENSION CORD		
Wire Size	Single Phase Hoist	Three Phase Hoist
#16 A.W.G.	135 ft (40m)	245 ft (73m)
#14 A.W.G.	220 ft (66m)	395 ft (120m)
#12 A.W.G.	354 ft (107m)	630 ft (192m)

115-1-50/60 units without contactor (hoists with orange control station)

Table 4b - Adequate Power Supply

LENGTH OF CONTROL CORD ft(m)	MAXIMUM LENGTH OF EXTENSION CORD BASED ON SIZE OF WIRE		
	#16 AWG	#14 AWG	#12 AWG
1.0 to 10.0 (0.3 to 3.0)	105ft (32m)	170ft (51m)	270ft (82m)
11.1 to 20.0 (3.1 to 6.0)	75ft (22m)	120ft (36m)	190ft (58m)
21.1 to 30.0 (6.1 to 9.0)	45ft (14m)	70ft (21m)	110ft (33m)
31.1 to 40.0 (9.1 to 12.0)	15ft (4.5m)	20ft (6m)	35ft (11m)

After the hoist is suspended from its support and you have made sure the power supply complies with the above, the hoist is ready for operation.

On the Double units, cut and discard the ties used to hold the two strands of chain together. With no load on the lower hook, depress the UP button in the control station and raise the lower hook until it is about 2 feet below the bottom of the hoist. Check both strands of chains for twists. Twists occur if the lower hook block has been capsized between the strands of chain during packing, shipment and/or handling. Reverse the capsize to remove twists.

OPERATING INSTRUCTIONS

The hoist is equipped with a Protector™ that is designed to allow the first gear to slip on an excessive overload. An overload is indicated when the hoist speed slows down, it raises the load in a jerky manner or it will not lift the load at all. Also, some clutching noise may be heard if the hoist is loaded beyond rated capacity. Should this occur, immediately release the UP button to stop the operation of the hoist. At this point, the load should be reduced to the rated capacity or the hoist should be replaced with one of the proper capacity. When the excessive load is removed, normal hoist operation is automatically restored.

CAUTION

The Protector™ is susceptible to overheating and wear when slipped for extended periods. Under no circumstance should the Protector be allowed to slip for more than a few seconds.

Due to the above, the hoist is not recommended for use in any application where there is a possibility of adding to an already suspended load to the point of overload. This includes dumbwaiter installations, containers that are loaded in mid-air, etc. Also, if the hoist is used at unusual extremes of ambient temperatures, above 150° F (65°C). or below 15°F (-9°C)., changes in lubricant properties may permit the hoist to raise larger loads than under normal operating conditions and present possibility of damage or injury.

On units without contactor (hoists with orange control station) it is necessary to stop the hoist before changing direction. Therefore, when lowering a load, the push button in the control station must be released momentarily before the UP button is depressed to raise the load. If this is not done, the hoist will continue to operate in the down direction while the UP push button is depressed, and it will continue to lower the load until the control push button is released. As a result, the direction must not be reversed quickly (plug reversed).

There are no electrical switches to stop the operation of the hoist at the upper and lower limits of lift. As a result, it is necessary to release the push button in the control station to stop the hoist components from damage. However, continued, prolonged or repeated slipping of the Protector will damage the Protector and cause overheating of the internal hoist components.

WARNING

Allowing the hook block to run into the hoist when raising a load or allowing the chain stop to run into the hoist when lowering a load may break the chain and allow the load to drop.

TO AVOID INJURY:

Do not allow the hook block or the chain stop to contact the hoist frame.

Hoist operation is controlled by depressing the control station push buttons. Depressing the UP push button will move the load hook toward the hoist head; depressing the DOWN push button will move the load hook away from the hoist head.

The UP and DOWN buttons are momentary type and the hoist will operate in the selected direction as long as the button is held in the depressed position. Release the push button and the hoist will stop.

It is preferred that the load always be tied off with auxiliary chains or cables before access to the area beneath the load is permitted. As an alternative, the system may be designed such that malfunction or failure of one hoist's load bearing components does not cause load loss and/or overloading of any other hoists in the system. Note that in such a system, hoist performance and function must be monitored visually or with the use of load cells. Check the supporting structure to which the load hook is to be attached. Make sure the attachment point as well as the structure have sufficient strength to withstand several times the load imposed. If in doubt, consult a registered engineer and local building codes.

WARNING

Attaching the load hook to an inadequate support may allow the hoist and load to fall and cause injury and/or property damage.

TO AVOID INJURY:

Make sure the structure and the load hook attachment point have sufficient strength to hold several times the hoist and rated load.

1. When preparing to lift a load, be sure that the attachments to the load hook are firmly seated in hook saddle. Avoid off center loading of any kind, especially loading on the point of the hook.
2. When lifting, raise the load only enough to clear the floor or support and check to be sure that the attachments to the hook and load are firmly seated. Continue lift only after you are assured the load is free of all obstructions.
3. Do not load the hoist beyond the rated capacity shown on the brake end cover. Overloading can cause immediate failure of some load-carrying part or create a defect causing subsequent failure at less than rated capacity. When in doubt, use the next larger capacity of hoist.
4. Do not use this or any other overhead materials handling equipment for lifting persons or allow people on unsecured load.
5. Stand clear of all loads and avoid moving a load over heads of other personnel. Warn personnel of your intention to move a load in their area. Do not leave unsecured load over people.
6. Do not leave the load suspended in the air unattended.
7. Permit only qualified personnel to operate unit.
8. Do not wrap the load chain around the supporting structure and hook onto itself as a choker chain. Doing this will result in:
 1. The loss of the swivel effect of the load hook which could mean twisted chain and a jammed liftwheel.
 2. The chain could be damaged at the load hook.
9. On the Double-reeved hoists, check for twists in the load chain. A twist can occur if the lower block has been capsized between the strands of chain. Reverse the capsize to remove twist.
10. Do not allow a load to bear against the hook latch. The latch is to help maintain the hook in position while the chain is slack before taking up the slack chain.
11. Take up a slack load chain carefully and start load easily to avoid shock and jerking of hoist chain. If there is any evidence of overloading, immediately lower the load and remove the excess load.
12. Do not allow the load to swing or twist while hoisting.
13. Never operate the hoist when flammable materials or vapors are present. Electrical devices produce arcs or sparks that can cause a fire or explosion.
14. **STAY ALERT!** Watch what you are doing and use common sense. Do not use the hoist when you are tired, distracted or under the influence of drugs, alcohol or medication causing diminished control.

WARNING

TO AVOID INJURY:

- DO NOT** Lift more than rated load.
- DO NOT** Operate with twisted, kinked or damaged chain.
- DO NOT** Operate damaged or malfunctioning hoist
- DO NOT** Lift people, loads over people, allow people on unsecured load or leave unsecured load over people.
- DO NOT** Operate hoist when load hook is not centered overhoist.
- DO NOT** Permit load hook block to contact hoist frame or chain container.
- DO** Replace damaged or malfunctioning hook latch.
- DO** Keep load chain well oiled.
- DO** Read ASME B30.16 Safety Code for Hoist and appropriate operating instructions.

MAINTENANCE

INSPECTION

To maintain continuous and satisfactory operation, a regular inspection procedure must be initiated to replace worn or damaged parts before they become unsafe. Inspection intervals must be determined by the individual application and are based on the type of service to which the hoist will be subjected. The type of service to which the hoist is subjected can be classified as "Severe", "Normal", or "Stand by Service" per ANSI E1.6-2.

Severe Service: Hoist operates in excess of 200 days a year.

Normal Service: Hoist operates 200 or fewer days a year but more than 25.

Stand by Service: Hoist operates 25 or fewer days per year but at least once per year.

Two classes of inspection - frequent and periodic – must be performed.

Frequent Inspections: Visual examination shall be performed by a competent person following the items listed in the inspection table. Records of such inspections are recommended.

Periodic Inspections: Inspection shall be performed by a qualified person following the items listed in inspection table. Records of this inspection shall be recorded and retained for a minimum of 36 months after the hoist is taken out of service.

Lifting and lowering functions shall be tested under no-load conditions. (Testing through complete rated lift length is not required). Brake(s) operation shall be tested under no-load conditions.

CAUTION

Any deficiencies found during inspections are to be corrected before the hoist is returned to service. Also, the external conditions may show the need for disassembly to permit a more detailed inspection, which, in turn, may require the use of nondestructive type testing.

PREVENTIVE MAINTENANCE

In addition to the above inspection procedure, a preventive maintenance program should be established to prolong the useful life of the hoist and maintain its reliability and continued safe use. The program should include the periodic and frequent inspections with particular attention being paid to the lubrication of the various components using the recommended lubricants (see page 15).

Note

To perform some of the periodic inspections, it is necessary to partially disassemble the hoist. Refer to Disassembly - Assembly starting on page 23.

Any deficiencies noted must be corrected before the hoist is returned to service. Also, the external conditions may show the need for more detailed inspection which, in turn, may require the use of nondestructive-type testing.

Any parts that are deemed unserviceable are to be replaced with new parts before the unit is returned to service. It is very important that the unserviceable parts be destroyed to prevent possible future use as a repair item and properly disposed of.

WARNING

Allowing a load to bear against the hook latch and/or hook tip can result in loss of load.

TO AVOID INJURY:

Do not allow a load to bear against the hook latch and/or hook tip. Apply load to hook bowl or saddle only

Table 5. Inspection Table						
Frequent Inspections	Service Classifications					ITEM
	Severe	Normal	Stand By	Rental	Out of Service	
	Weekly to Monthly	Monthly	Every 3 Months	Prior to Next Use or Rental		
Periodic Inspections	Every 3 Months	Yearly	Yearly	Yearly	Yearly	Prior to Reintroduction into Service
						Hoist braking system for proper operation.
						Hooks and attachment hardware for correct assembly, damage, cracks, twists, excessive throat openings, latch engagement, and latch operation.
						Load chain for adequate lubrication, signs of wear, damaged links, corrosion, or foreign matter.
						Load chain for proper reeving and twists.
						Limit switches for function, if equipped
						All items listed in Inspection Table for frequent inspections.
						Evidence of loose screws, bolts or nuts.
						Evidence of worn, corroded, cracked or distorted hook block body, suspension screws, gears, bearings, chain dead end and chain pin.
						Evidence of damage or excessive wear of the lift wheel and hook block sheave chain pockets.
						Link by link inspection of the chain for evidence of excessive interlink wear and damage.
						Evidence of chain guide wear or damage where the chain enters the hoist.
						Evidence of excessive wear and/or damage of brake parts. Proper brake adjustment.
						If the hoist is equipped with a reversing contactor, inspect contactors for functionality and free operation of the interlock.
					Electrical cords, grommets, connectors, cables, and control station enclosure (if applicable) for damage or wear.	
					Check bearings for excessive wear or damage.	
					Suspension components for damage, cracks, wear and correct operation.	
					Evidence of lubricant leakage.	

HOOK INSPECTION

Hooks damaged from chemicals, deformations or cracks, or any visibly apparent bend or twist from the plane of the unbent hook, excessive opening or seat wear must be replaced. Also, hooks that are opened and allow the latch to not engage the tip must be replaced. Any hook that is twisted or has excessive throat opening indicates abuse or overloading of the unit. Inspect other load sustaining parts, hook block screws, load pins and hook block bodies for damage.

On latch type hooks, check to make sure that the latch is not damaged or bent and that it operates properly with sufficient spring pressure to keep the latch tightly against the tip of the hook and allow the latch to spring back to the tip when released. If the latch does not operate properly, it should be replaced. See Figure 8 to determine when the hook must be replaced.

Suspension bolts should be replaced any time the suspension is removed from the hoist.

HOOK REPLACEMENT CRITERIA

Based on ASME B30.10, hooks shall be removed from service if damage such as the following is visible and shall only be returned to service when approved by a qualified person:

1. Missing or illegible rated load identification or illegible hook manufacturers' identification or secondary manufacturer's identification.
2. Excessive pitting or corrosion. Cracks, nicks, or gouges.
3. Wear--any wear exceeding 10% of the original section dimension of the hook or its load pin.
4. Deformation--any visibly apparent bend or twist from the plane of the unbent hook.
5. Throat opening--any distortion causing an increase in the throat opening of 5% not to exceed 1/4" (6mm).
6. Inability to lock- any self-locking hook that does no lock.
7. Inoperative latch, any damaged latch or malfunctioning latch that does not close the hook's throat.

8. Thread wear, damage, or corrosion.
9. Evidence of excessive heat exposure or unauthorized welding.
10. Evidence of unauthorized alterations such as drilling, machining, grinding, or other modifications.

INSPECTING THE LOAD CHAIN

The chain must be inspected at regular intervals, with a minimum of once annually. As the frequency of use increases, the time intervals between inspections must be reduced. During inspection, the chain link must be examined along their entire length, including the hidden parts. If the lifting equipment is frequently used with a constant lifting distance or in other words the switch from upward to downward often takes place in the same area, a particularly thorough inspection and lubrication is required in that area. Worn chain can also be an indication of worn hoist components. For this reason, the hoist's chain guides, hook blocks and liftwheel (sprocket) should be examined for wear and replaced as necessary when replacing chain.

1. Check to see if chain is dirty or poorly lubricated.
2. Clean the chain with a non-caustic/non-acid type solvent and make a link by link inspection for wear or cracks in the links, twisted or deformed links. Chain with any one of these defects must be replaced.
3. Slack the portion of the chain that normally passes over the lift-wheel (sprocket) or idler sprocket on multi-reeved hoist. Examine the chain links for wear. If the wire diameter anywhere on the link measures less than 90% of the nominal wire diameter, the chain must be replaced.
4. Based upon ASME B30.16, should also be checked for elongation. Select an unworn, un-stretched length of the chain (at the slack end for example). Suspend the chain vertically under tension and using a knife blade caliper type gauge, measure the outside length of any convenient number of links, 11 is recommended. Measure the same number of links in the used sections and calculate the percentage in increased length. The chain should be replaced if the length of the used portion is more than 1.5% longer than the unused portion of the chain. Also, if the pitch of any individual link has elongated by more than 5%, the chain should be replaced.

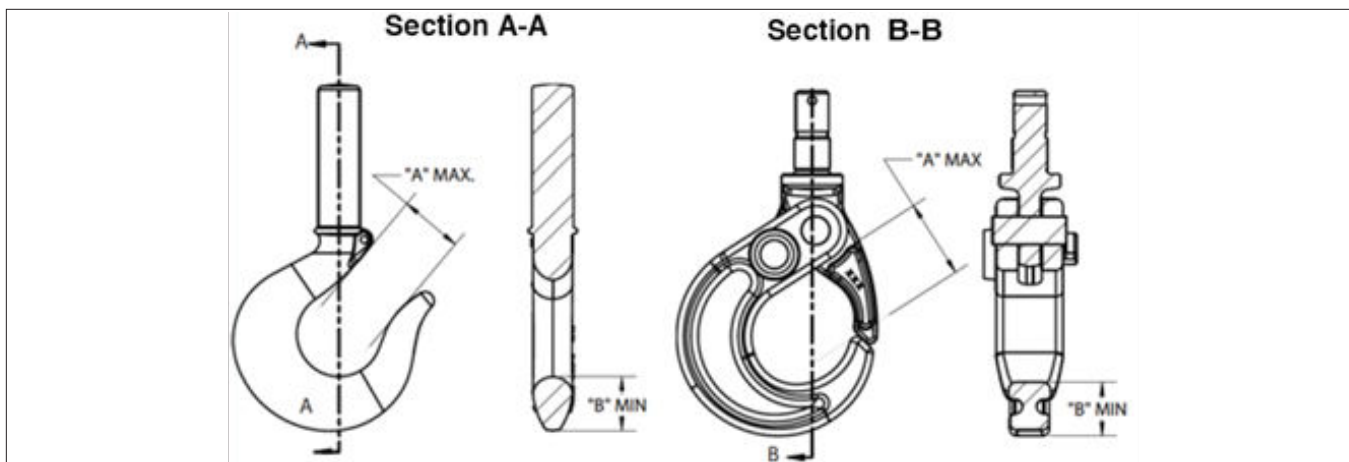

Figure 10 - Hook Inspection

Latch Type Hook		Latchlok® Hook	
"A" Max	"B" Min	"A" Max	"B" Min
1.12" (28.5mm)	.71" (18.0mm)	1.48" (37.7mm)	.75" (18.8mm)

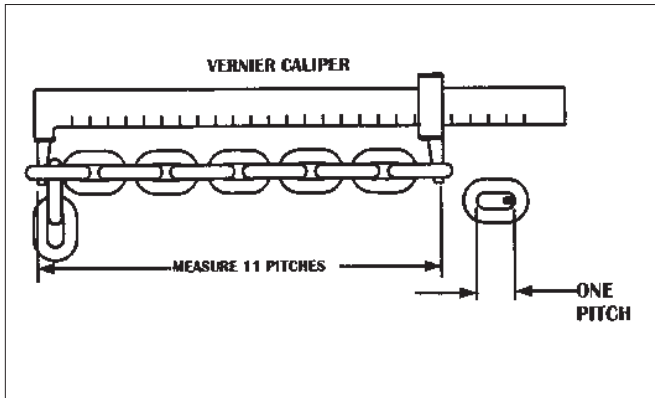

Figure 11: Chain Inspection

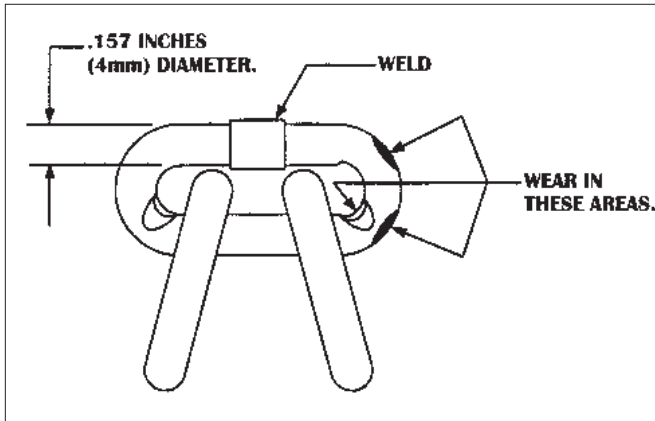
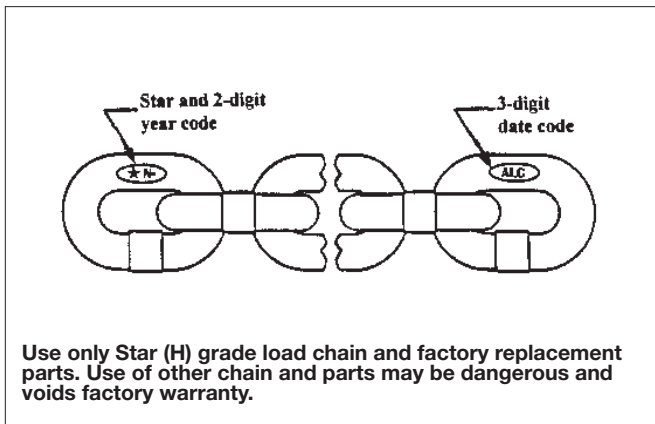

Figure 12: Chain Wear Areas



Use only Star (H) grade load chain and factory replacement parts. Use of other chain and parts may be dangerous and voids factory warranty.

Figure 13: Chain Identification

Use only Star (*) grade load chain and original replacement parts. Use of other chain and parts may be dangerous and voids factory warranty.

IMPORTANT: Do not use replaced chain for other purposes such as lifting or pulling. Load chain may break suddenly without visual deformation. For this reason, cut replaced chain into short lengths to prevent use after disposal.

⚠ WARNING
Use of commercial or other manufactures' chain and parts to repair hoists may cause load loss.
TO AVOID INJURY:
Use only factory supplied replacement load chain and parts. Chain and parts may look alike, but our chain and parts are made of specific materials or processed to achieve specific properties.

Use only a "Knife-edge" caliper to eliminate possibility of false reading by not measuring full pitch length.

Note that worn chain can be an indication of worn hoist components. For this reason, the hoist's chain guide, hook block and liftwheel should be examined for wear and replaced as necessary when replacing worn chain.

Also, these chains are specially heat treated and hardened and should never be repaired.

IMPORTANT: Do not use replaced chain for other purposes such as lifting or pulling. Load chain may break suddenly without visual deformation. For this reason, cut replaced chain into short lengths to prevent use after disposal.

CHAIN LUBRICATION

A small amount of lubricant will greatly increase the life of load chain. Do not allow the chain to run dry.

Keep it clean and lubricate at regular intervals with Lubriplate® Bar and Chain Oil 10-R (Fiske Bros. Refining Co.) or equal lubricant. Normally, weekly lubrication and cleaning is satisfactory, but under hot and dirty conditions, it may be necessary to clean the chain at least once a day and lubricate it several times between cleaning.

When lubricating the chain, apply sufficient lubricant to obtain natural run-off and full coverage, especially in the interlink area.

⚠ WARNING
Used motor oils contain known carcinogenic materials.
TO AVOID HEALTH INJURIES
Never use used motor oils as a chain lubricant. Only use Lubriplate® Bar and Chain Oil 10-R as a lubricant for the load chain.

LUBRICATION

To assure extra long life and top performance, be sure to lubricate the various parts of the Shopstar Hoist using the lubricants specified below. If desired, these lubricants may be purchased from the factory. Contact customer service for more information.

⚠ WARNING
The lubricants used in and recommended for the Shopstar Hoist may contain hazardous materials that mandate specific handling and disposal procedures.
TO AVOID CONTACT AND CONTAMINATION:
Handle and dispose of lubricants only as directed in applicable material safety data sheets and in accordance with applicable local, state and federal regulations.

Part Number for Packaged Lubricants used on the Shopstar Electric Chain Hoists		
Lubricant Usage	Type of Lubricant	Part Numbers and Packaged Quantity of Lubricants
Hoist Gears	Grease (Special)	28605
Lower Hook Thrust Bearing	*Oil	Heavy Machine Oil obtain locally

*These oils are not furnished by CM in Packaged Quantities. When ordering lubricants, specify the type of lubricant, part number and packages quantity required.

GEARS

The Protector (620-111) should operate for the normal life of the hoist without service. The device has been lubricated and calibrated by the factory and should not be adjusted.

CAUTION

The Protector™ is to be used with “Century Lubricants HB-11, #3” grease. Do not use any other grease or the Protector will not operate properly and parts could be damaged.

The gears and Protector are packed at assembly with grease and should not need to be renewed unless the gears have been removed from the housing and degreased.

CAUTION

Never degrease the Protector™ or attempt to disassemble this device. Degreasing the Protector may damage parts and using a device that has been degreased may cause erratic, inconsistent operation. If the Protector has been degreased, it must be replaced by a factory calibrated device.

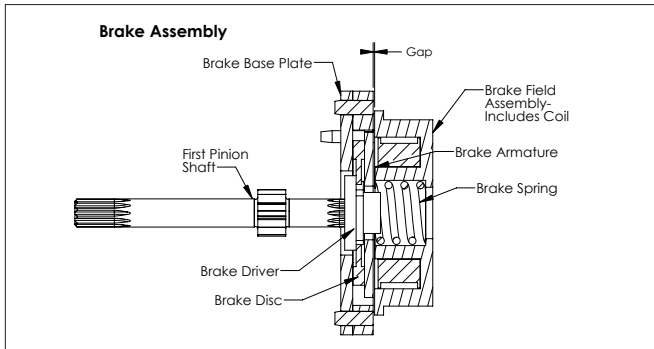

Figure 14: Brake Field Assembly

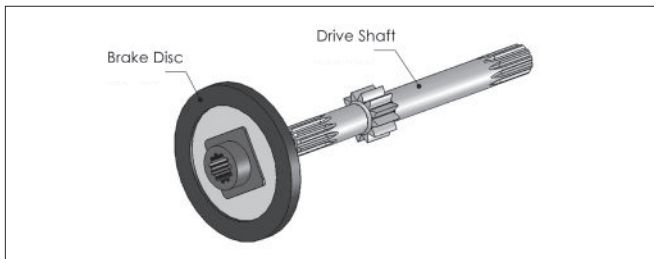

Figure 15: Drive Shaft Assembly

If the gears are removed from the housing, wipe the excess grease off the outside surfaces of the Protector with a soft cloth and degrease the remaining gears and housings. Upon reassembly, add 2 oz. of the above grease to gears and housing. Also, coat the spline on the end of the first pinion and shaft with a Molydisulphide lubricant such as Moly-Duolube 67 (Hercules Packing Co.)

BEARINGS

Rotor bearings are pre-lubricated and require no lubrication. Needle bearings are packed at assembly with grease and should not need to be relubricated. However, if the housings, liftwheel or sheave wheel have been degreased, these bearings should be greased using “Century Lubricants HB-11, #3” grease.

SEALS

When reassembling the unit, wipe the inside surface of the seals with “Century Lubricants HB-11, #3” grease.

HOOK BLOCK

If the hook blocks are disassembled for inspection purposes, wipe the grease from the hook knob and the hook knob cavities in the hook blocks. At reassembly, coat the underside of the hook knob and the knob bearing surfaces of cavities in the hook blocks with Molykote BR-2-S (Dow Corning Corp.) grease or equivalent.

CHAIN GUIDE, LIFTWHEEL AND SHEAVE WHEEL

When the hoist is disassembled for inspection and/or repair, the chain guide, stripper, sheave wheel (on double chain unit) and liftwheel must be lubricated with Lubriplate® Bar and Chain Oil 10-R (Fiske Bros. Refining Co.) prior to reassembly. The lubricant must be applied in sufficient quantity to obtain natural runoff and full coverage of these parts.

LOAD CHAIN

Refer to page 13 for lubrication of the load chain.

EXTERIOR FINISH

The exterior surface of the hoist has a durable, scratch resistant baked powder coating. Normally, the exterior surfaces can be cleaned by wiping with a cloth. However, if the finish is damaged, compatible touch-up paint can be purchased from the factory. Refer to page 19 for information on ordering the paint.

ELECTRIC BRAKE

The brake is non-adjustable with a nominal .004 inch (0.102 mm) air gap and the brake disc must be replaced when the air gap reaches .012 inch (0.305 mm). The brake spacer should be no more than .012 inch (0.305 mm) thicker than the combined thickness of the brake disc and armature plate. Refer to Figure 16.

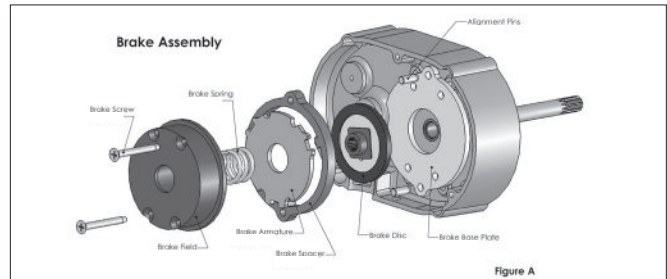

Figure 16: Brake Assembly

WARNING

Failure to follow proper lockout/tagout procedures may present the danger of electrical shock.

TO AVOID INJURY:

Disconnect power and lockout/tagout disconnecting means before removing cover or servicing this equipment.

To inspect the brake gap, disconnect the hoist from power and remove brake end cover.

1. Refer to Figure 16 and disassemble the brake. Depress and hold the field assembly while removing the four brake screws. The field assembly is under spring pressure and will spring-out if not held. Examine the base plate, brake disc) and armature for excessive wear, scoring or warpage. Make sure the brake disc is not glazed, the coil firmly fixed in the field) and the brake spring is not damaged. Worn, scored, warped, glazed or damaged parts should be replaced before proceeding.
2. Refer to Figure 16 and assemble the brake. Depress and hold the field assembly while installing the four brake screws through the brake parts and mount the brake on the gear housing. Tighten the four brake screws to 25 in.lb.

PROTECTOR™

The Protector should operate for the normal life of the hoist without service. The device has been lubricated and calibrated and it should not be adjusted. If the Protector is not operating properly (see testing on page 13), it must be replaced with a properly calibrated unit from the factory.

PREVENTATIVE MAINTENANCE

A preventative maintenance program should be established to prolong the useful life of the hoist and maintain its reliability and continued safe use. The program should include the periodic and frequent inspections with particular attention being paid to the lubrication schedule on page 12.

TROUBLESHOOTING CHART

Always disconnect unit from the power supply system before removing hoist covers or the back cover of control station.

Symptom	Possible Cause(s)	Corrective Action
1. Hook does not respond to the control station	A.) No voltage at hoist-main line or branch circuit switch open; branch line fuse blown or circuit breaker tripped.	A.) Check for blown fuse or tripped circuit breaker or open disconnect switch in main line or branch circuit. Replace fuse, reset circuit breaker or close switch.
	B.) Open control circuit due to loose connections or broken wires in circuit; motor thermal protector open; control station contacts not closing; open or Shorted winding in transformer; transformer thermal cut-out open; mechanical binding in contactor; open or shorted winding in contactor coil or blown Printed Circuit Board fuse.	B.) Check electrical continuity thru motor thermal protector. If it is open, allow motor to cool. If this does not correct the trouble, use wiring diagram to check electrical continuity of wiring, transformer, contactor and control station contacts. Repair wiring or replace defective part. Check Printed Circuit Board fuse & replace if needed.
	C.) Wrong voltage or frequency.	C.) Make sure that the power supply to hoist is the same as that shown on identification plate on button of hoist.
	D.) Low Voltage.	D.) Check power supply system to make sure it complies with the requirements listed under "power supply system" starting on page 3.
	E.) Brake not releasing due to open or shorted coil, defective diodes or brake disc binding.	E.) Check coil continuity, diodes and connections. Make sure brake disc slides freely on brake driver and brake spring is not broken. Replace coil (brake field), repair connections, remove burrs from brake driver so that brake disc slides freely and/or replace brake spring.
	F.) Excessive load.	F.) Reduce load to capacity limit as indicated on identification and capacity labels on hoist.
	G.) Phase failure (single phasing-three phase units only) - open circuit, grounded or faulty connection in one line of power supply system, hoist wiring, contactor, motor leads or windings.	G.) Check for electrical continuity and repair or replace defective part.
2.) Hook moves in the wrong direction.	A.) Wiring connections reversed in control station or hoist.	A.) Use wiring diagram and check wiring connections.
	B.) Failure of cut-out device (single phase units only) to effect dynamic braking at time of reversal.	B.) Check connections to cut-out device. Replace damaged device or faulty capacitor
	C.) Phase reversal (three phase unit only).	C.) See "Three Phase Hoists."
3.) Hook lowers but will not raise.	A.) Excessive load.	A.) See item 1F.
	B.) Hoisting circuit is OPEN due to loose connections or broken wire in circuit; control station contacts are not making; open or shorted winding in contactor coil.	B.) Use wiring diagram to check electrical continuity of wiring and control station contacts. Repair wiring or replace defective part.
	C.) Motor cut-out device not operating. (single phase units only).	C.) Check cut-out device and connections to same. Repair connections and/or replace cut-out device.
	D.) Phase failure (three phase units only).	D.) See item 1G.
4.) Hook raises but will not lower.	A.) Lowering circuit is OPEN due to loose connections or broken wire; control station contacts not closing; open or shorted winding in contactor coil.	A.) See item 1B.
	B.) Motor reversing switch not operating (single phase unit only).	B.) See item 3C
	C.) Phase reversal (three phase units only).	C.) See item 2C
	D.) Phase failure (three phase units only).	D.) See item 1G.
5.) Hook does not stop promptly.	A.) Brake slipping.	A.) Check electric brake, especially the brake disc for wear or glazing and make sure brake spring is not broken. Replace worn or glazed brake disc or replace brake spring.
	B.) Excessive load.	B.) See item 1F.

Symptom	Possible Cause(s)	Corrective Action
6.) Hoist operates sluggishly.	A.) Excessive load.	A.) See item 1F.
	B.) Low voltage.	B.) See item 1D.
	C.) Phase failure or unbalanced current in the phases (three phase unit only).	C.) See item 1G.
	D.) Brake dragging.	D.) Check electric brake. Check to make sure brake disc is free to move on brake driver. Check for warped or bent brake disc and base plate. Free-up brake disc by removing burrs on driver. Replace warped armature base plate or brake disc.
7.) Hoist operates sluggishly.	A.) Excessive load.	A.) See item 1F.
	B.) Low voltage.	B.) See item 1D.
	C.) Extreme external heat.	C.) Above an ambient temperature of 104°F (40°C), the frequency of hoist operation must be limited to avoid overheating the motor. Special provisions should be made to ventilate the space around the hoist and shield it from radiant heat.
	D.) Frequent starting or reversing.	D.) Avoid excessive inching, jogging and reversing. This type of operation drastically shortens motor cut-out device, capacitor, control station and contactor contact life and causes excessive brake wear.
	E.) Brake dragging.	E.) See item 6C.
	F.) Motor cut-out device not opening start winding circuit (single phase units only).	F.) See item 3C.
	G.) Phase failure or unbalanced current in phases (three phase units only).	G.) See Item 1G.
8. Hook fails to stop in either direction.	A.) Brake not closing or ineffective.	A.) Check electric brake, and armature for binding, broken brake spring, first pinion shaft broke, brake driver worn, brake disc worn. Correct binding of armature; replace broken or worn parts.
9. Hook lowers when up button is depressed.	A.) Phase reversal (three phase units only).	A.) See Item 2C.

WARNING

Failure to follow proper lockout/tagout procedures may present the danger of electrical shock.

TO AVOID INJURY:

Disconnect power and lockout/tagout disconnecting means before removing cover or servicing this equipment.

ELECTRICAL DATA

OPEN OR SHORT CIRCUIT IN ELECTRICAL COMPONENTS

Open circuits in electrical components may be detected by isolating the component and checking for continuity using an ohmmeter. Short circuits are indicated by D.C. resistance substantially below the nominal D.C. resistance. Motor current draw should be measured at the end of the power cord while the hoist is raising rated load. Check cut-out device (on single phase units only) by measuring coil resistance (terminals 3 and 4) and making sure the contact (terminals 2 and 4) is open.

Table 6 - Electrical Data for Components

Stators					
Volts-Phase-Hertz	Full Load Current (amp)			Nominal DC Resistance (ohm)	
110 to 120-1-50/60	2.7			Yellow to Red: 7.7 Blue to Black: 6.2	
220-1-50	1.1			Yellow to Red: 27.7 Blue to Black: 24.2	
220-3-50	1.1			White to Red: 26.8 White to Black: 26.8	
230-3-60	0.6			Red to Black: 26.8	
380-3-50	0.63			White to Red: 72.6	
415-3-50	0.58			White to Black: 72.6	
460-3-60	0.88			Red to Black: 72.6	
575-3-60	0.4			White to Red: 140.0 White to Black: 140.0 Red to Black: 140.0	
Transformers					
Primary	220/380v.	230/460v.	460v.	575v.	575v.
Secondary	48v.	115v.	48v.	115v.	48v.
Leads	Nominal DC Resistance (ohm)				
Black to Purple	11.7	71.0	11.9	73	98
White to Red	228.0	224.0			
White to Yellow	614.0	902.0			
Red to Yellow	384.0	682.0			
White to Orange			916.0	1100	1100

Coils			
	Voltage (V)	Current Draw (amp)	Nominal DC Resistance (ohm)
Contactor Coils	115	0.02	765
	48	0.2	98.4
Brake Field	*115	-	*272
	**220	-	1120
	***280	-	1608
Cut-out Device	*115	0.1	Terminals 3 to 4: 0.3

*to measure 115 volt brake coil resistance, carefully cut and peel back the shrink tubing on the brake coil leads to expose the diodes. Trace the leads from the coil to the diodes. Connect the ohmmeter leads at the coil side of the diodes (refer to the wiring diagram) and measure the resistance. If coil is ok, reinsulate the brake coil leads and diodes using electrical tape. Diodes are checked by connecting the ohmmeter to the ends of the brake coil leads, checking for an open or short circuit, reversing the connections to the ohmmeter and again checking for an open or short circuit. If there is an indication of an open or short circuit with the original and reversed connections, diodes are defective and the brake field, which includes the diodes, must be replaced. Usable diodes are indicated by continuity with the original connections and an open circuit when the connections are reversed or, an open circuit with the original connection and continuity with reversed connections.

** 220 volt brake coil is used on 220-1-50, 220-3-50/60, 380-3-50, 415-3-50 and 460-3-60 hoists.

***280 volt brake is used on 575-3-60 hoists.

CAUTION

To reduce the risk of electric shock or injury, use indoors only.

DISASSEMBLY-ASSEMBLY

When disassembling and assembling the Shopstar Hoist, refer to the exploded view and the parts list on pages 15 through 18. These show the proper relationship of the parts, the names of the parts and the required quantities of the parts. In addition, please observe the following:

1. Needle bearings are pressed into the gear housing, main frame, liftwheel and lower sheave wheel. Unless they are to be replaced, do not attempt to remove these bearings.
2. A liftwheel seal is pressed into the main frame and a seal is pressed into the end of the liftwheel shaft. Be careful that these seals are not cut or damaged during disassembly and reassembly.

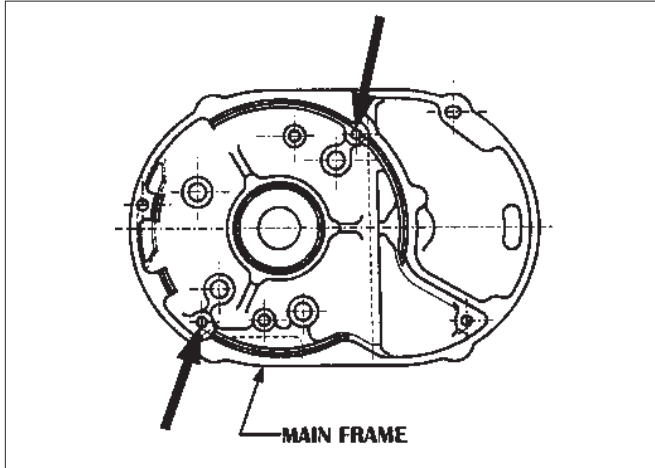

Figure 17 - Main Frame

3. Refer to page 13 for disassembly, inspection, reassembly and adjustment of the brake.
4. Do not attempt to disassemble the Protector™ - refer to page 13.
5. Refer to page 14 for lubrication instructions.
6. See next section for load chain removal and installation.
7. Tighten the various screws as follows:

Table 7 - Torque Settings

Part Name	Seating lb-in	Torque (N-m)
Pin Retainer Plate Screw	25	2.8
Motor Cover Screw	25	2.8
Gear Housing Screw	25	2.8
Brake End Cover Screw	25	2.8
Dead End Plate Screw	125	14.1
Hook Retainer Screw	10	1.1
Hook Block Screw, Double-reeved, 500, 600 and 1,000 lb (226, 272 and 453 kg)	72-78	8-9
Hook Block Screw, Single-reeved, 250, 300 and 500 lb (113, 136 and 226 kg)	72-78	8-9
Power Cord Ground Screw	20	2.2

8. When removing the stator, first remove the brake end cover. Disconnect stator leads from the wiring or contactor. At the other end, remove the motor end cover. On single phase units, use an insulated screw driver to short between the bare terminals of the capacitor to discharge it. A spark may be produced. Disconnect wiring to the capacitor and then remove the capacitor. Remove the cut-out device and disconnect the wires from it. Remove the rotor assembly and thrust washer. Then slide the stator out of the main frame.

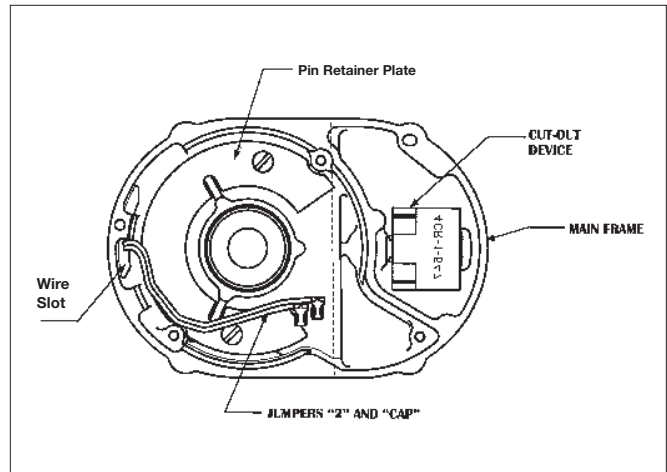

Figure 18 - Stator Installation

9. To install the stator, (Refer to Figure 17) and make sure that the pin retainer plate has been assembled to the main frame. On single phase units slide jumpers "2" and "CAP" through the wire slot in the main frame. Route these wires around the rotor bearing boss in the main frame as shown in Figure 18. Attach the brown and blue stator leads and "2" jumper to cut-out device (refer to wiring diagram). Slide the cut-out device into the cavity as shown. Push the cut-out device down until it sets on the main frame. Place the capacitor on top of the cut-out device and attach "CAP" jumper and the yellow stator lead to it. Re-route jumpers "2" and "CAP", if necessary to make sure they clear the rotor bearing boss as shown in Figure 18. On all units slide stator leads through wire slot. Align the slots in the stator shell with the threaded holes in the main frame, as shown in Figure 17. With the leads down, slide the stator into the main frame. Slide the rotor, large bearing first, into stator. Place the rotor thrust washer on top of the exposed rotor bearing and then assemble the motor end cover to the main frame. Using wiring diagram, complete the wiring at the brake end of the unit.
10. Properly install the upper hook as shown in Figure 20, then slide the hook retainer into the cavity on top of the hoist and secure it using hook retainer screw. Tighten screw to a seating torque of 10 in. lbs. (1.1 NM).

LOAD CHAIN REMOVAL/INSTALLATION

1. If unit has a chain container, remove it from the chain guide.
2. Remove the chain stop. Depress DOWN button and run chain out of hoist.

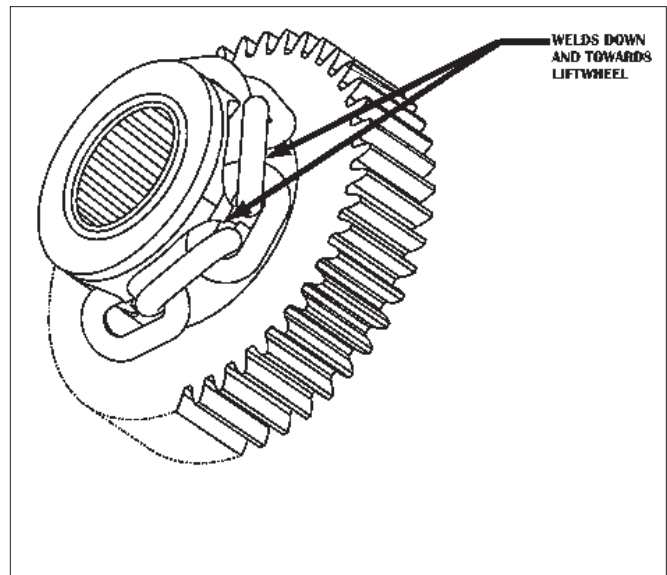

Figure 19: Chaining Hoist

3. Feed a short length of soft wire through the opening in the chain guide/stripper until it comes out of the hoist. Attach "new" chain to end of the wire which is in the center of the hoist. Position the chain so that the welds will be down and towards the liftwheel as shown above in Figure 19.
4. Jog the UP push button while pulling on the free end of wire until the chain comes out of the hoist. Remove the wire and attach the chain stop as shown in Figure 21. On units with chain container, place chain stop and loose end of chain in chain container. Attach chain container to chain guide.
5. On the 250, 300 and 500 lbs (single reeved), (113, 136 and 226 kg) units, remove the hook block from the old chain and attach it to the new chain by reusing the chain pin. On the 500, 600 and 1000 lbs (226, 272 and 453 kg) units:

- Remove dead end plate from hoist.
- Remove dead end pin from the last link of chain and pull chain out of dead end plate.
- Pull old chain out of hook block and disassemble the hook block.
- Make sure the new chain is not twisted and wrap the chain around the sheave wheel with welds down and towards the sheave wheel.
- Reassemble hook block and pull the new chain through the hook block.
- Slide the dead end plate over the last link and secure it using the dead end pin.

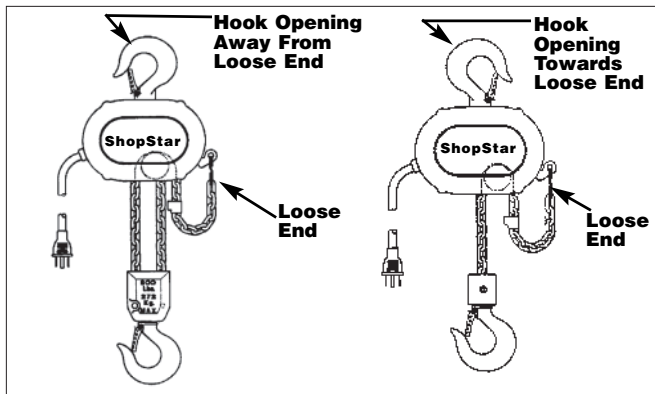

Figure 20 - Chaining Diagram

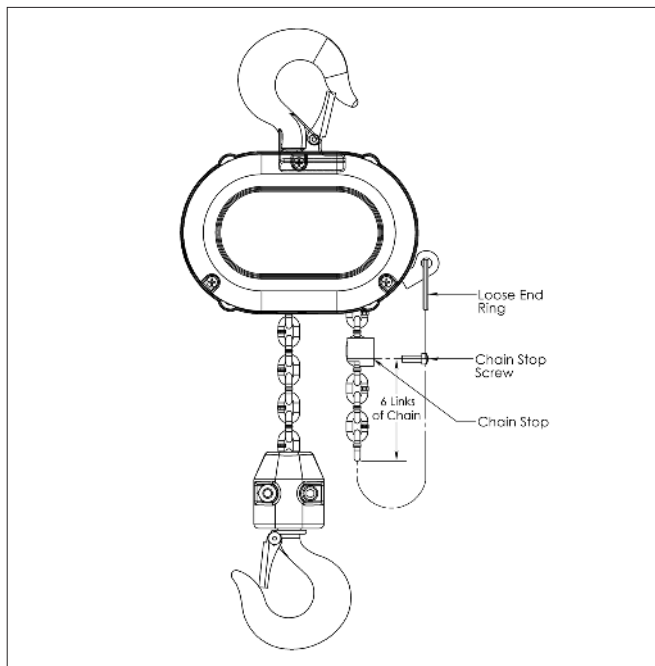

Figure 21 - Chain Stop

- Making sure the chain is not twisted between the hook block and hoist, attach the dead end plate to the chain guide/stripper.
- Retrace the new chain and check for twists. If chain is twisted, start over.

IMPORTANT: Do not use "old" chain for other purposes such as lifting or pulling. Load chain may break suddenly without visual deformation. For this reason, cut the "old" chain into short lengths to prevent use after disposal.

CUTTING CHAIN

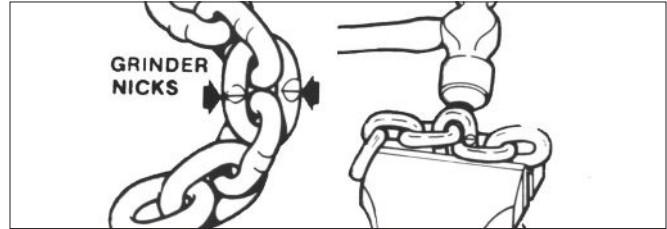

Figure 22 - Cutting Chain by Nicking

Hoistaloy® load chain is hardened and it is difficult to cut. The following methods are recommended when cutting a length of new chain from stock or cutting off worn chain. Always wear eye protection when cutting chain.

1. Use a grinder and nick the link on both sides (see right), then secure the link in a vise and break off with a hammer.
2. Use a 7" (177 mm) minimum diameter by 1/8" (3.1 mm) thick abrasive wheel (or type recommended by wheel supplier) that will clear adjacent links.

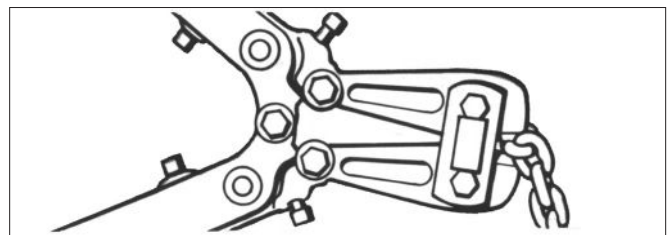

Figure 23 - Cutting Chain with a Bolt Cutter

WARNING

Cutting chain can produce flying particles.

TO AVOID HEALTH PROBLEMS:

- Wear eye protection.
- Place a shield over chain to prevent flying objects.

3. Use a bolt cutter (see right) with special cutter jaws for cutting hardened chain. Jaws should be 1 inch (25.4 mm) long.

TESTING

Before using, all altered, repaired or used hoists that have not been operated for the previous 12 months must be tested by the user for proper operation. First, test the unit without a load and then with a light load of 50 pounds (23 kg) times the number of load supporting parts of load chain to be sure that the hoist operates properly and that the brake holds the load when control is released. Next test with a load of *125% of rated capacity. In addition hoists in which load sustaining parts have been replaced should be tested with *125% of rated capacity by or under the direction of an appointed person and written report prepared for record purposes. After this test, check that the Protector functions. If the Protector permits lifting a load in excess of 200% of rated load, it should be replaced.

*If the Protector prevents lifting of a load of 125% of rated capacity, reduce load to rated capacity.

REPAIR PARTS LIST

 WARNING
Using "Commercial" or other manufacturer's parts to repair the CM Shopstar Hoists may cause load loss.
TO AVOID INJURY
Use only CM supplied replacement parts. Parts may look alike but CM parts are made of specific materials or processed to achieve specific properties.



ORDERING INSTRUCTIONS

The following information must accompany all correspondence orders for replacement parts:

1. Hoist Model Number from identification plate.
2. Serial number of the hoist stamped below identification plate.
3. Voltage, phase, hertz from the identification plate.
4. Length of lift.
5. Part number of part from parts list.
6. Number of parts required.
7. Part name from parts list.

Note
When ordering replacement parts, it is recommended that consideration be given to the need for also ordering such items as gaskets, fasteners, insulators, etc. These items may be damaged or lost during disassembly or just unfit for future use because of deterioration from age or service.

RECOMMENDED SPARE PARTS

To insure continued service of the Shopstar Hoist, the following is a list of parts that are recommended to be kept on hand at all times to replace parts that have worn or failed. Parts applicable to your hoist should be stocked.

	Part Name	Part Quantity
Contact manufacturer	Brake field assem.	1
20698	Brake disc	1
Contact manufacturer	Capacitor	1
20709	Cut-out device	1
Contact manufacturer	Transformer	1
Contact manufacturer	Reversing contactor	1
Contact manufacturer	Control station	1
Contact manufacturer	Control station parts kit	1

WARRANTY

LIMITATION OF WARRANTIES, REMEDIES AND DAMAGES

INDEMNIFICATION AND SAFE OPERATION

Buyer shall comply with and require its employees to comply with directions set forth in instructions and manuals furnished by Seller and shall use and require its employees to follow such instructions and manuals and to use reasonable care in the use and maintenance of the Goods and any Replacement Parts. Buyer shall not remove or permit anyone to remove any warning or instruction signs on the Goods or Replacement Parts. In the event of personal injury or damage to property or business arising from the use of the Goods or Replacement Parts, Buyer shall within 48 hours thereafter give Seller written notice of such injury or damage. Buyer shall cooperate with Seller in investigating any such injury or damage and in the defense of any claims arising therefrom.

If Buyer fails to comply with this section or if any injury or damage is caused, in whole or in part, by Buyer's failure to comply with applicable federal or state laws, rules or regulations safety requirements, Buyer shall indemnify and hold Seller harmless against any claims, loss or expense for injury or damage arising from the use of the Goods and/or Replacement Parts.

CMCO Warranty (HOISTS)

A. Columbus McKinnon Corporation ("Seller") warrants to the original end user ("Buyer") that: (a) for a period of one (1) year from the date of Seller's delivery of the goods (collectively, the "Goods") to the carrier, the electrical components of the Goods will be free from defects in workmanship and materials; and (b) for the life of the Goods, the mechanical components of the Goods will be free from defects in workmanship and materials. In addition, Seller warrants to Buyer that, for a period of one (1) year from the date of their delivery by Seller to the carrier, any aftermarket or replacement parts, accessories or components purchased by Buyer with respect to any Goods (collectively, "Replacement Parts") will be free from defects in workmanship and materials.

B. IN THE EVENT OF ANY BREACH OF ANY SUCH WARRANTY, SELLER'S SOLE OBLIGATION SHALL BE EXCLUSIVELY LIMITED TO, AT THE OPTION OF SELLER, REPAIR OR REPLACEMENT, F.O.B. SELLER'S POINT OF SHIPMENT, OF ANY GOODS OR REPLACEMENT PARTS THAT SELLER DETERMINES TO HAVE BEEN DEFECTIVE OR, IF SELLER DETERMINES THAT SUCH REPAIR OR REPLACEMENT IS NOT FEASIBLE, TO A REFUND OF THE PURCHASE PRICE UPON RETURN OF THE GOODS OR REPLACEMENT PARTS TO SELLER. NO CLAIM AGAINST SELLER FOR ANY BREACH OF (i) SUCH WARRANTY WITH RESPECT TO THE ELECTRICAL COMPONENTS OF ANY GOOD, OR ANY REPLACEMENT PART, SHALL BE VALID OR ENFORCEABLE UNLESS BUYER'S WRITTEN NOTICE THEREOF IS RECEIVED BY SELLER WITHIN ONE (1) YEAR FROM THE DATE OF SELLER'S DELIVERY TO THE CARRIER AND (ii) SUCH WARRANTY WITH RESPECT TO THE MECHANICAL COMPONENTS OF ANY GOOD SHALL BE VALID OR ENFORCEABLE UNLESS BUYER'S WRITTEN NOTICE THEREOF IS RECEIVED BY SELLER WITHIN ONE (1) YEAR FROM THE DATE THE DATE ANY ALLEGED CLAIM ACCRUES. EXCEPT FOR THE WARRANTIES SET FORTH ABOVE, SELLER MAKES NO OTHER WARRANTIES WITH RESPECT TO THE GOODS OR ANY REPLACEMENT PART, WHETHER EXPRESSED OR IMPLIED, INCLUDING ANY WARRANTIES OF MERCHANTABILITY, FITNESS FOR A PARTICULAR PURPOSE, QUALITY AND/OR THOSE ARISING BY STATUTE OR OTHERWISE BY LAW OR FROM ANY COURSE OF DEALING OR USE OF TRADE, ALL OF WHICH ARE HEREBY EXPRESSLY DISCLAIMED.

C. IN NO EVENT SHALL SELLER BE LIABLE TO BUYER OR ANY THIRD PARTY WITH RESPECT TO ANY GOOD OR REPLACEMENT PART, WHETHER IN CONTRACT, TORT OR OTHER THEORY OF LAW, FOR LOSS OF PROFITS OR LOSS OF USE, OR FOR ANY INCIDENTAL, CONSEQUENTIAL, SPECIAL, DIRECT OR INDIRECT DAMAGES, HOWSOEVER CAUSED. SELLER'S MAXIMUM LIABILITY TO BUYER WITH RESPECT TO THE GOODS OR ANY REPLACEMENT PART SHALL IN NO EVENT EXCEED THE PRICE PAID BY BUYER FOR THE GOODS OR REPLACEMENT PART THAT ARE THE SUBJECT OF THE APPLICABLE CLAIM.

D. Seller shall not be liable for any damage, injury or loss arising out of the use of the Goods or any Replacement Part if, prior to such damage, injury or loss, such Goods or Replacement Parts are: (1) damaged or misused following Seller's delivery to the carrier; (2) not maintained, inspected, or used in compliance with applicable law and Seller's written instructions and recommendations; or (3) installed, repaired, altered or modified (a) with any part or accessory other than those supplied by Seller or (b) without compliance with such laws, instructions or recommendations.

E. This warranty is limited and provided only to the original end user. **Each Good and Replacement Part must be registered within sixty (60) days of receipt of each product to establish eligibility.** Please register at www.cmworks.com/hoist-warranty-registration or submit registration card via US mail.

F. Any action against Seller for breach of warranty, negligence or otherwise in connection with the electrical components of any Good must be commenced by Buyer within one (1) year after: (a) the date any alleged claim accrues; or (b) the date of delivery of the Goods to Buyer, whichever is earlier. Any action against Seller for breach of warranty, negligence or otherwise in connection with the mechanical components of any Good must be commenced by Buyer within one (1) year after the date any alleged claim accrues. Any action against Seller for breach of warranty, negligence or otherwise in connection with any Replacement Part must be commenced by Buyer within one (1) year after: (y) the date any alleged claim accrues; or (z) the date of delivery of the Replacement Part to Buyer, whichever is earlier.

G. This warranty is contingent upon Buyer's proper maintenance and care of the Goods and/or Replacement Parts, and does not extend to normal wear and tear. Seller reserves the right, at its option, to void this warranty in the event of Buyer's use with the Goods and/or Replacement Parts of parts or accessories other than those supplied by Seller.

WARNING

Alterations or modifications of equipment and use of non-Seller replacement parts can lead to dangerous operation and injury.

TO AVOID INJURY:

- Do not alter or modify equipment.
- Do use only replacement parts manufactured by Seller.



USA: Ph: (800) 888.0985 • (716) 689.5400 • Fax: (716) 689.5644 • www.cmworks.com

CANADA: Ph: (877) 264.6478 • Fax: (877) 264.6477 • www.cmworks.com

GERMANY: Ph: +49 7940 128-0 • Fax +49 7940 55665 • www.stahlcranes.com

Partners In Motion Control