

# ShopAir™ chain hoist

**Compact, powerful, and precise for assembly and manufacturing applications up to 1,000 pounds.**

The CM ShopAir combines superior lifting speeds, rugged design, and precise load spotting in a portable air chain hoist. As a workstation hoist or a production line hoist, the ShopAir is the ideal choice.

---

**CAPACITIES:** 250 to 1,000 Lbs.

**NORMAL OPERATING PRESSURE:** 90 PSI (6.2 bar)

**AIR CONSUMPTION:** 34 cu.feet/min.

---

- Standard Protector™ overload device.
- 10-pocket, oblique lay liftwheel provides longer chain life.
- Epoxy powder coat finish provides a durable exterior.
- Durable reduction gearing means reliable operation
- Variable flow, two lever pendant for precise load spotting.
- Threaded external exhaust for piping away exhaust in clean room or painting applications.
- Small, compact design for commercial & industrial applications.
- Industrial duty air motor for tough applications.
- Gear train is lifetime lubricated with non-oxidizing grease.
- Hardened forged steel, latch-type lower hook rotates 360°.
- Hardened forged steel, rigid latch-type upper hook.
- Rugged cast aluminum alloy hoist frame.
- Alloy load chain.
- Maximum pendant drop - 36 ft.
- Lifetime warranty against defects in materials and workmanship.
- Made in U.S.A.



# ShopAir™ air chain hoist

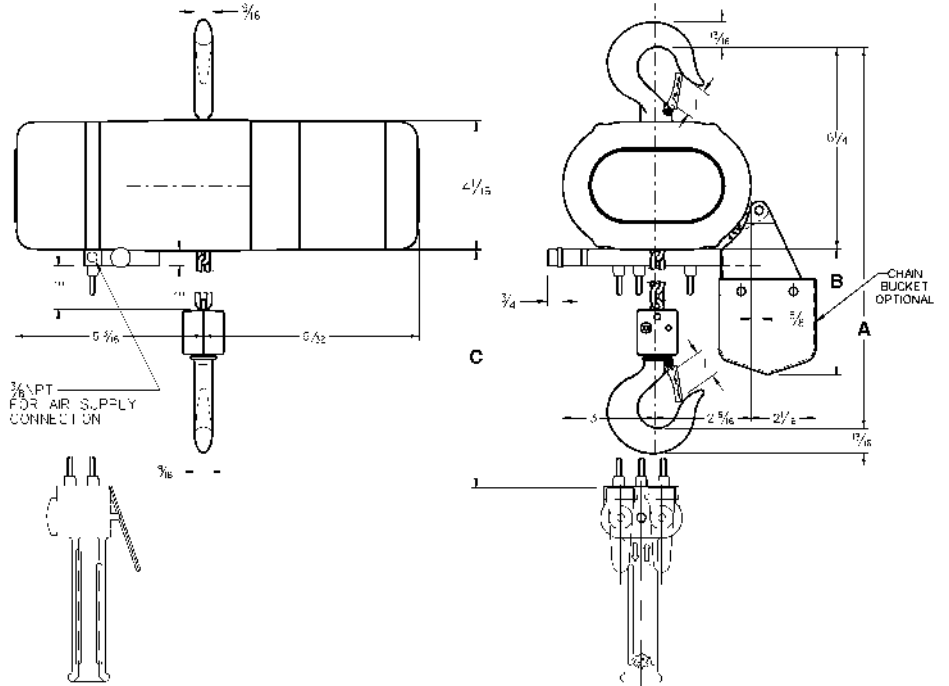

## Specifications

Product code	Cap. (lbs.)	(in.)			Number of load chains	Speed FPM (under full load)		Shipping weight (lbs.)
		A	B	*C		lifting	lowering	
2178	250	10 <sup>7</sup> / <sub>8</sub>	3 <sup>7</sup> / <sub>8</sub>	6' 4"	1	31	83	30
2180	300	10 <sup>7</sup> / <sub>8</sub>	3 <sup>7</sup> / <sub>8</sub>	6' 4"	1	31	83	30
2182	500	10 <sup>7</sup> / <sub>8</sub>	3 <sup>7</sup> / <sub>8</sub>	6' 4"	1	21	75	30
2179	500	11 <sup>15</sup> / <sub>16</sub>	5 <sup>3</sup> / <sub>4</sub>	6' 4"	2	16	42	34
2181	600	11 <sup>15</sup> / <sub>16</sub>	5 <sup>3</sup> / <sub>4</sub>	6' 4"	2	16	42	34
2183	1,000	11 <sup>15</sup> / <sub>16</sub>	5 <sup>3</sup> / <sub>4</sub>	6' 4"	2	11	38	34

300 Lb. model shown with optional chain container

## \* ⚠ WARNING

Overloading and improper use can result in injury.

### To avoid injury:

- Do not exceed working load limit, load rating capacity
- Do not use to lift people or loads over people.
- use only alloy chain for overhead lifting.
- Read and follow all instructions.