

CM[®]

LODESTAR[®] VS

VARIABLE SPEED ELECTRIC CHAIN HOIST WITH **INTELLI-CONNECT[™]**



MAGNETEK

The Drive Inside[™]



C O L U M B U S M C K I N N O N C O R P O R A T I O N

The Power of Intelligent Lifting. Generations of users have relied on the CM[®] Lodestar[®] electric chain hoist for the durability and reliability it provides for lifting applications. With the Lodestar VS, Columbus McKinnon made this iconic hoist better than ever. We combined the Lodestar's industry-leading design with the best-in-class features of premier Magnetek[®] variable frequency drives and Intelli-Connect[™] Diagnostic and Analytic technology. The result — a one-of-a-kind, intelligent hoist that puts the power to program, maintain, monitor, and troubleshoot the hoist in the palm of your hand.

Using the Intelli-Connect Mobile and Mobile+ apps, you can wirelessly access detailed hoist information right from the plant floor, without the need for a programming cable. With information available at your fingertips, you can easily adjust performance parameters, address issues more quickly, plan maintenance, and ultimately reduce downtime.

**INTELLI-
CONNECT™**



**The
Drive
Inside™**





CM
LODESTAR[®]
VS

192045464

MAGNETEK
The Drive Inside



LODESTAR[®] VS

VARIABLE SPEED ELECTRIC CHAIN HOIST

CAPACITIES: 1/8 TO 3 TONS

STANDARD LIFT: 10 FEET

STANDARD FEATURES

LESS MAINTENANCE & EASY INSPECTION

- Brake location allows for quick access and easy inspection.
- Lifetime grease-lubricated gear box means no oil change out is required. Precision gears provide better wear and longer life.
- Clutch located outside the gear box allows for easy access, which eliminates the need for complete disassembly and reduces downtime.

IMPROVED SERVICEABILITY

Easy access to the clutch, motor, electrical control panel and brake assembly.

LONG SERVICE LIFE

- Heavy-duty DC brake is designed for a long service life.
- Lifetime grease-lubricated gear box and helical gearing ensures better wear and smooth operation.
- Heavy-duty rated motor.

QUIET OPERATION

80% reduction in sound pressure as compared to the classic Lodestar.

IMPROVED LOAD SAFETY

Clutch is located outside the load path, preventing slipping of the load in an overload condition when the brake is not powered.

LONG CHAIN LIFE

5-pocket lift wheel provides excellent chain and lift wheel engagement for smoother lifting and reduced vibration, equating to less wear and a longer chain life. Zinc plating protects chain from environmental conditions.

EASY ACCESS CONTROL PANEL

Finger-safe wiring and plug-and-play connectors on the control panel allow for easy access to the variable frequency drive (VFD).

ZINC-PLATED LOAD CHAIN

Designed and manufactured in the USA by Columbus McKinnon. Zinc-plated Star Grade load chain protects against corrosion.

EXCEEDS H4 REQUIREMENTS

Lodestar exceeds H4 requirements. Engineered for high duty cycles and the toughest applications.

ECO-FRIENDLY

Lifetime grease-lubricated gear box means no changing and disposing of hazardous oil. Documented RoHS compliance. Shipped in boxes made of recycled material.

METRIC RATED

LIFETIME WARRANTY

The industry's best warranty against manufacturing and material defects.

FABRIC CHAIN CONTAINER

Standard up to 20 ft. lift.

RIGID HOOK SUSPENSION

COMPACT, DURABLE PENDANT

2-step hoists furnished with CM Rocket pendant as standard. Pushbutton pendant is optional.

3-step hoists furnished with pushbutton pendant as standard. CM Rocket pendant not available for 3-step models.

Both pendants are designed for operator comfort, NEMA 4X (IP65) approved for indoor or outdoor industrial service and temperature rated for 0°C (32°F) to 70°C (158°F). Available with and without emergency stop button.

OPTIONAL FEATURES

ADDITIONAL LOAD CHAIN OPTIONS

Black phosphate, burnished in oil, DIN grade and Ni clad (nickel) plated load chain also available.

METAL & STAINLESS STEEL CHAIN CONTAINERS

Pushbutton
Pendant >>



<< CM[®] Rocket[™]
Pendant

LOOK WHAT'S DRIVING YOUR HOIST

If you're looking for unsurpassed VFD performance, look no further than the Lodestar VS featuring the Magnetek IMPULSE®•G+ Mini drive. Modern in design, Magnetek drives provide reliable, user-friendly controls and come equipped with industry-leading safety features to keep you working safely. Paired with the Intelli-Connect Mobile and Mobile+ apps, operators can easily adjust and monitor hoist performance and get on-the-spot diagnostic and analytic information, increasing efficiency and reducing downtime.

PRECISION LOAD CONTROL FOR MICRO-POSITIONING

Programmable hoist speeds, acceleration/deceleration rates, and speed control give the operator unsurpassed micro-positioning capabilities while decreasing load bounce.

LONGER HOIST, BRAKE & MOTOR SERVICE LIFE

Electronically programmable upper and lower limit switches (EPLS) allow users to ramp down to stop, decreasing load bounce and increasing brake life. No jogging necessary. Limits can be easily set and modified with CM HI-Tech™ (Hoist Interface Technology) within our Intelli-Connect Mobile and Mobile+ apps. Variable frequency drives offer built-in thermal overload and overcurrent protection for the hoist motor.

INCREASED EFFICIENCY WITH SWIFT-LIFT™

Swift-Lift™ feature increases operator efficiency, allowing the hook to move 200% faster when the hoist is not under load.

For example, if a hoist is programmed for 60 fpm, the hook will move at 120 fpm not under load (any load that is less than or equal to 20% of the hoist's capacity).

OVERLOAD AND OVER-SPEED PROTECTION

When enabled, the Load Check II™ feature monitors capacity and prevents overloading if capacity is exceeded. Modified openloop vector control with gearbox-mounted speed sensor protects against over-speed and speed deviation.

EASILY ADJUST & MONITOR HOIST PERFORMANCE

The Lodestar VS equipped with Intelli-Connect puts performance and status information at your fingertips.

Using the Intelli-Connect Mobile and Mobile+ apps, you can choose the control method of the hoist, as well as the maximum, minimum and, if applicable, medium speed of the hoist. It also allows you to easily set upper and lower limits as well as SwiftLift parameters.

HIGHER DUTY CYCLES

Heat sink and brake resistor (mounted inside of the hoist) allow for maximum heat dissipation and uninterrupted drive service at high-duty cycles. Hoists are not equipped with load brakes, reducing heat generation in high-duty-cycle applications.

FLEXIBLE CONFIGURATIONS

Standard 2-step infinitely variable control with acceleration and deceleration control. Optional 3-step infinitely variable control as well as 2 and 3 speed multi-step controls. Available for single-phase and 3-phase applications.



THE **CM** ADVANTAGE

Only Columbus McKinnon can offer the legendary durability of the CM Lodestar together with Magnetek, the premier name in drive controls. For unsurpassed performance, look for "The Drive Inside" emblem on your next variable frequency drive hoist.



INTELLI-CONNECT™

DIAGNOSTICS AND ANALYTICS

The Lodestar VS is now available with Intelli-Connect Diagnostics and Analytics as an option. Intelli-Connect enables quick and easy programming, maintenance, monitoring, and troubleshooting of the Lodestar – all from a tablet or smartphone. How does it work? Using the Intelli-Connect Mobile and Mobile+ apps, you can wirelessly access detailed information right from the plant floor, without the need to attach a programming cable. Intelli-Connect is available as an option on all new Lodestar VS units or in a retrofit kit for units already in service.

INTELLI-CONNECT MOBILE

Intelli-Connect Mobile is comprised of a wireless operator module (WOP-20) mounted on the hoist that is connected to the Magnetek VFD inside the Lodestar VS. The wireless operator creates a wireless network, which is accessible from a personal electronic device (PED), such as a smartphone or tablet. Once linked, Intelli-Connect Mobile enables quick and easy programming, maintenance, monitoring, and troubleshooting of the hoist. The mobile app is available as a free download on Google Play or the Apple® App Store®*.

FEATURES

- Easy hoist setup
- Access to the latest user manuals and troubleshooting guides
- Ability to adjust parameters and store backup sets to the wireless operator or PED
- Quick access to parameters with the ability to set parameter favorites based on frequent use
- Functionality to easily copy a parameter set from one Magnetek VFD and upload onto another
- Access to technical support through the app for parameter setup and troubleshooting
- Over-the-air updates for wireless operator
- Detailed event logging of faults and alarms
- Secure Wi-Fi connection between wireless operator and personal electronic device
- Includes all features of CM HI-Tech interface previously available with the Lodestar VS

*Google Play is a trademark of Google LLC. Apple and App Store are registered trademarks of Apple Inc., registered in the U.S. and other countries.

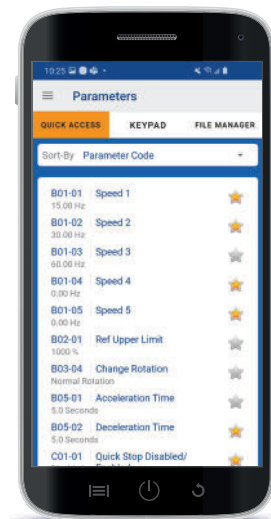
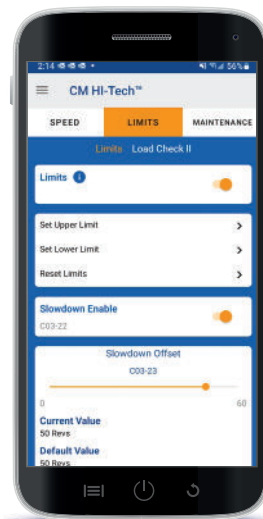
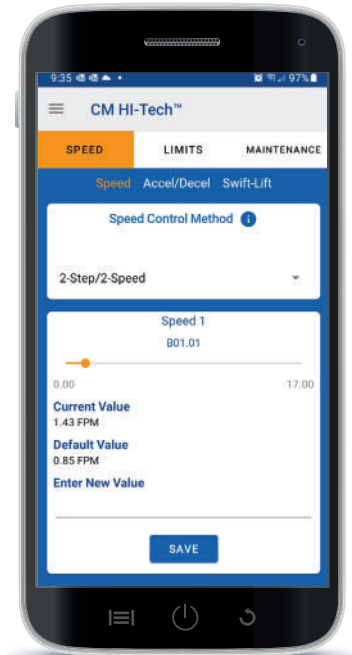

INTELLI-CONNECT MOBILE+

Intelli-Connect Mobile+ provides you with all the capabilities of Intelli-Connect Mobile, along with advanced diagnostics and analytics, including trending data and event logging as well as the remaining operating life of the hoist. With this additional information, you'll be able to easily coordinate maintenance schedules to keep downtime to a minimum and ultimately save money. Upgrade to Mobile+ functionality for a one-time fee through the Intelli-Connect Mobile App.

FEATURES

- Continuous monitoring of pre- and post-VFD events and trending data
- Ability to trigger data-logging events
- Visibility to remaining hoist life, which requires the optional Lodestar internal load cell or a 3rd party load cell
- Expanded fault and alarm history
- Inspection log to track maintenance notes



WHY UPGRADE TO MOBILE+?

With the upgraded Intelli-Connect Mobile+, you can continuously monitor your hoist and track trends over a period of time. It tracks long-term information, providing a comprehensive view of your hoist by monitoring runs, faults, alarms, and VFD status, including fault codes, motor voltage, current, available hoist operating life, and more. In the event that regulatory or company standards apply to your hoist, you can also keep track of inspection notes right in the Mobile+ app.

With Intelli-Connect Mobile+, you'll be able to:

- View continuous trending data
- Plan maintenance and inspections
- Predict when to repair or purchase equipment
- Put service teams in place for quick repairs
- Utilize manuals in the app to troubleshoot and recover quickly from faults and alarms

With more VFD information at your fingertips, you'll be able to keep equipment operating safely and efficiently to ensure the highest levels of productivity in your facility.

FEATURES	Intelli-Connect Mobile	Intelli-Connect Mobile +
One-to-One Connection from App to IMPULSE G+ Mini VFD	•	•
CM HI-Tech PC Interface	•	•
Monitoring of VFD Current, Torque, Digital I/Os, etc.	•	•
Fault Reset	•	•
Read and Write Subset of Parameters (Quick Access)	•	•
Operator Emulator Mode (LCD and Buttons)	•	•
Upload and Download VFD Parameter Files	•	•
IMPULSE®-Link 5 Compatible Files	•	•
Device Documentation Access (Manuals, Help Screens, etc.)	•	•
Secure Wi-Fi Connection: SSID Name and Password	•	•
Trending Logs and Run/Fault/Alarm Logs		•
Hoist Service Life (Requires a Load Cell)		•
Maintenance and Inspection Log		•
Monitor and Trend Subsets		•
Event Log with Trigger and Time/Date Stamp		•

THE ANATOMY OF THE LODESTAR VS

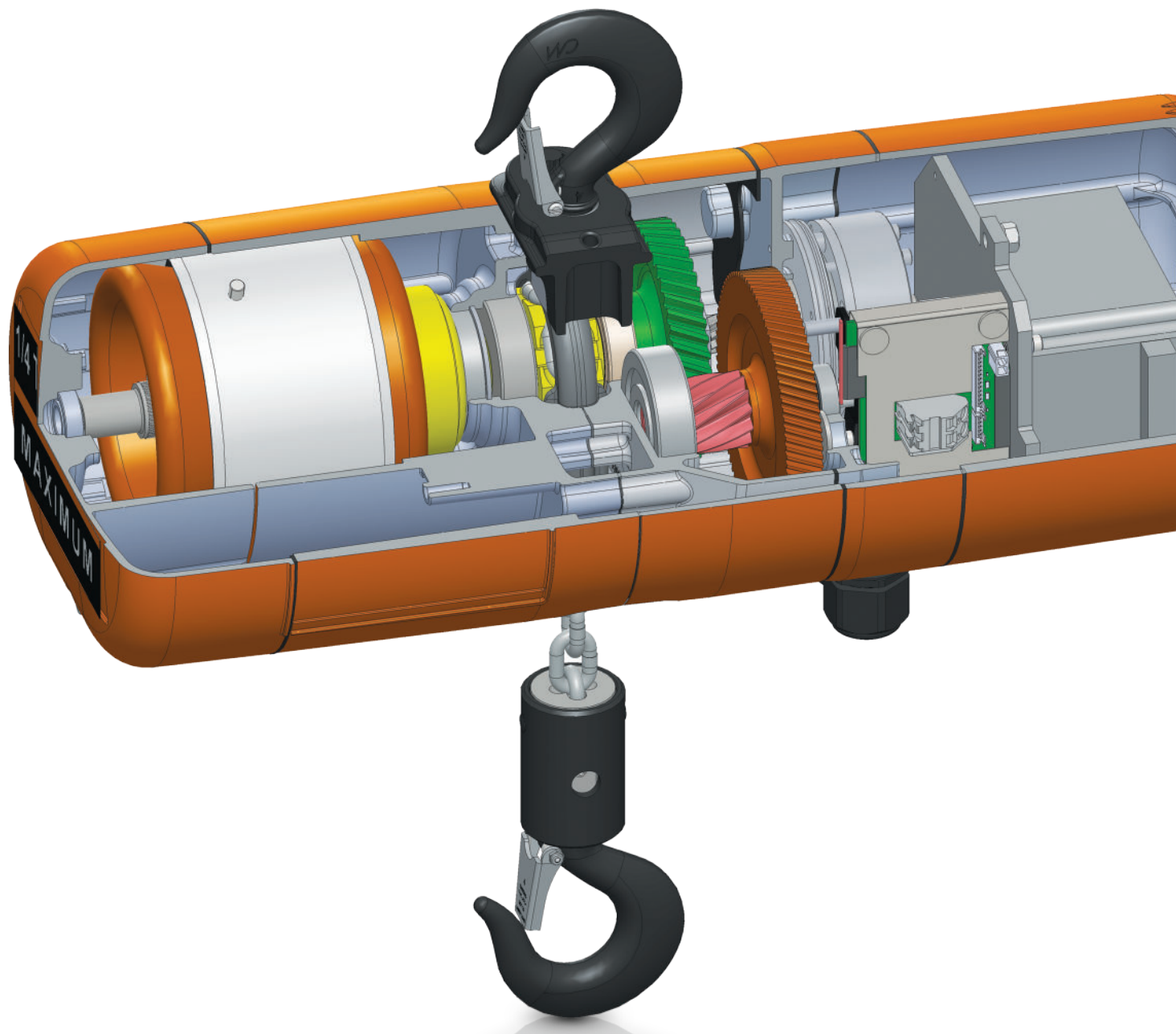

THE IDEAL WORKSTATION HOIST

The CM Lodestar VS is ideal for applications in the automotive, heavy OEM, utility and energy industries. Choose this reliable hoist for assembly workstations that require high speed and precision control lifting with light rail or trolley systems.

In addition, the Lodestar VS is perfect for maintenance and repair applications demanding accurate load control or long lifts.



KEY COMPONENTS

Working together, these high-quality components provide best-in-class performance for any application in a wide variety of industries.



Gear Box

Precision helical gearing is grease lubricated for quiet, smooth operation and long service life.



Lift Wheel

5-pocket wheel increases engagement of the chain to provide smooth lifting with less vibration and reduced chain wear when properly maintained – extending the life of the chain.



Clutch

Located outside the gear box for easy access, the clutch is designed to prevent lifting loads greater than rated capacity.



Internal Chain Guide

The stamped steel chain guide, coated for corrosion resistance and quiet operation, keeps the load chain and liftwheel aligned during operation.



Cast Aluminum Housing

Acid-resistant, powder-coated finish for superior durability and protection against elements. Sealed drive shaft and standard weather-proofing gasket and seals for an IP66 rating* — suitable for outdoor use. Highly visible and recognizable CM orange color.

**NOTE: CM Rocket Pendant is IP65 rated*



Hook Suspension

Rigid upper hook is standard on every Lodestar. Swivel hook, as well as push, hand-gear and motorized trolley suspensions are optional.



Brake

Heavy-duty DC brake is standard.



Load Chain & Hook

Hoistaloy™ load chain and forged steel hook are manufactured in the USA by Columbus McKinnon – ensuring the highest quality standards are met at all times. Chain is zinc plated for protection against corrosion and is 100% proof tested.



Fabric Chain Container

Standard on every Lodestar. Recommended for applications where slack chain would interfere with the load or drag on the floor. Fabric chain container standard on units with lifts up to 20 ft.



Motor

Both heavy duty and efficient, the motor is designed to operate on power supplies worldwide. Standard Class F insulation and thermal motor protection.

MAXIMUM CONTROL. MINIMAL EFFORT.

Compared to traditional straight grip and pushbutton configurations, the CM Rocket Pendant's comfort-fit design and responsive rocker switch give operators maximum control with minimal effort.

At the heart of the CM Rocket is a unique rocker switch that is ergonomically designed to reduce thumb strain while allowing for ultimate micro-positioning load control – all for increased safety and efficiency.

The Rocket's curved and ribbed design helps ensure a secure and comfortable grip.

Available in single- and 2-speed configurations, with or without an emergency stop button.

The Rocket pendant is not available for CM Lodestar VS hoists with 3-step controls or for units configured with motorized trolleys.



CM LODESTAR VS

SPECIFICATIONS & DIMENSIONS

STANDARD LIFT: 10 FT

Capacity (tons)	Model	Product Code	Hoist Lifting Speed (FPM)	Reeving	Control Type	Power Supply	Dimensions (Latch-Type Upper and Lower Hooks) inches (mm)												Weight with Hook Susp. (lbs.)
							A	B	C	D	E	F	G	H	I	J	K	L	
1/8	A	LV01321D102MA	32	1	2-Step, Multi-Step	115-1-60	8.82 (223.84)	11.69 (296.86)	.69 (17.46)	3 (76.2)	.69 (17.46)	4.44 (112.71)	4.25 (107.95)	.94 (23.81)	3.00 (76.20)	17.63 (447.68)	1 (25.4)	1.13 (28.58)	75
		3-Step Int Variable			115-1-60														
		2-Step, Multi-Step			230-3-60														
		3-Step Int Variable			230-3-60														
		2-Step, Multi-Step			460-3-60														
1/8	AA	LV01601D102MA	60	1	2-Step, Multi-Step	115-1-60	8.82 (223.84)	11.69 (296.86)	.69 (17.46)	6 (152.4)	.69 (17.46)	4.44 (112.71)	4.25 (107.95)	.94 (23.81)	3.00 (76.20)	17.63 (447.68)	1 (25.4)	1.13 (28.58)	75
		3-Step Int Variable			115-1-60														
		2-Step, Multi-Step			230-3-60														
		3-Step Int Variable			230-3-60														
		2-Step, Multi-Step			460-3-60														
1/4	B	LV02161D102MA	16	1	2-Step, Multi-Step	115-1-60	8.82 (223.84)	11.69 (296.86)	.69 (17.46)	3 (76.2)	.69 (17.46)	4.44 (112.71)	4.25 (107.95)	.94 (23.81)	3.00 (76.20)	17.63 (447.68)	1 (25.4)	1.13 (28.58)	75
		3-Step Int Variable			115-1-60														
		2-Step, Multi-Step			230-3-60														
		3-Step Int Variable			230-3-60														
		2-Step, Multi-Step			460-3-60														
1/4	C	LV02321D102MA	32	1	2-Step, Multi-Step	115-1-60	8.82 (223.84)	11.69 (296.86)	.69 (17.46)	3 (76.2)	.69 (17.46)	4.44 (112.71)	4.25 (107.95)	.94 (23.81)	3.00 (76.20)	17.63 (447.68)	1 (25.4)	1.13 (28.58)	75
		3-Step Int Variable			115-1-60														
		2-Step, Multi-Step			230-3-60														
		3-Step Int Variable			230-3-60														
		2-Step, Multi-Step			460-3-60														
1/2	E	LV05082D102MA	8	2	2-Step, Multi-Step	115-1-60	8.82 (223.84)	11.69 (296.86)	.81 (20.64)	1.5 (38.1)	.81 (20.64)	3.44 (87.31)	5.25 (133.35)	1.13 (28.58)	-	19.56 (496.89)	1.13 (28.58)	1.25 (31.75)	90
		3-Step Int Variable			115-1-60														
		2-Step, Multi-Step			230-3-60														
		3-Step Int Variable			230-3-60														
		2-Step, Multi-Step			460-3-60														
1/2	F	LV05161D102MA	16	1	2-Step, Multi-Step	115-1-60	8.82 (223.84)	11.69 (296.86)	.69 (17.46)	3 (76.2)	.69 (17.46)	4.44 (112.71)	4.25 (107.95)	.94 (23.81)	3.00 (76.20)	17.63 (447.68)	1 (25.4)	1.13 (28.58)	75
		3-Step Int Variable			115-1-60														
		2-Step, Multi-Step			230-1-60														
		3-Step Int Variable			230-1-60														
		2-Step, Multi-Step			460-3-60														
1/2	J	LV05321D102MA	32	1	2-Step, Multi-Step	115-1-60	10 (254)	12.94 (328.68)	.81 (20.57)	3 (76.2)	.81 (20.57)	6.94 (176.28)	5.69 (144.53)	1.13 (28.7)	4.29 (108.9)	18.13 (460.5)	1.13 (28.7)	1.25 (31.75)	135
		3-Step Int Variable			115-1-60														
		2-Step, Multi-Step			230-3-60														
		3-Step Int Variable			230-3-60														
		2-Step, Multi-Step			460-3-60														
1	H	LV10082D102MA	8	2	2-Step, Multi-Step	115-1-60	8.82 (223.84)	11.69 (296.86)	.81 (20.64)	1.5 (38.1)	.81 (20.64)	3.44 (87.31)	5.25 (133.35)	1.13 (28.58)	-	19.56 (496.89)	1.13 (28.58)	1.25 (31.75)	90
		3-Step Int Variable			115-1-60														
		2-Step, Multi-Step			230-3-60														
		3-Step Int Variable			230-3-60														
		2-Step, Multi-Step			460-3-60														
1	L	LV10161D102MA	16	1	2-Step, Multi-Step	115-1-60	10 (254)	12.94 (328.68)	.81 (20.57)	1.5 (38.1)	.81 (20.57)	6.94 (176.28)	5.69 (144.53)	1.13 (28.7)	3.48 (88.41)	18.13 (460.5)	1.13 (28.7)	1.25 (31.75)	135
		3-Step Int Variable			115-1-60														
		2-Step, Multi-Step			230-1-60														
		3-Step Int Variable			230-1-60														
		2-Step, Multi-Step			460-3-60														
2	R	LV20082D102MA	8	2	2-Step, Multi-Step	115-1-60	10 (254)	12.94 (328.68)	1.13 (28.7)	1.5 (38.1)	1.13 (28.7)	5.69 (144.53)	6.94 (176.28)	1.5 (38.1)	4.29 (108.9)	25.81 (655.57)	1.5 (38.1)	1.5 (38.1)	155
		3-Step Int Variable			115-1-60														
		2-Step, Multi-Step			230-3-60														
		3-Step Int Variable			230-3-60														
		2-Step, Multi-Step			460-3-60														
3	RT	LV30053D102MA	5.5	3	2-Step, Multi-Step	115-1-60	10 (254)	12.94 (328.68)	1.13 (28.7)	1 (25.4)	1.13 (28.7)	5.31 (134.87)	7.31 (185.67)	1.5 (38.1)	4.92 (124.9)	29.31 (744.47)	1.5 (38.1)	1.37 (34.8)	180
		3-Step Int Variable			115-1-60														
		2-Step, Multi-Step			230-3-60														
		3-Step Int Variable			230-3-60														
		2-Step, Multi-Step			460-3-60														

NOTE: Fabric chain containers included on all models for up to 20 ft. lift. When ordering, specify code number(s), model, capacity, beam size, power supply, suspension, lift, extra control cord or power cord, (if required) and type of electrification (if required). For a full list of dimensions (including for hoists configured with bullard hooks, Latchlok hooks, or trolleys), see CM Lodestar VS Dimension Drawing Book.

SMALL FRAME (MODELS A, AA, B, C, E, F, H)

For hoists with latch-type upper and lower hooks

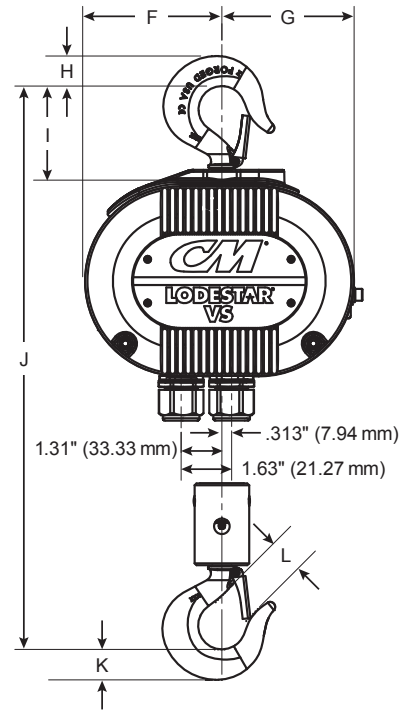
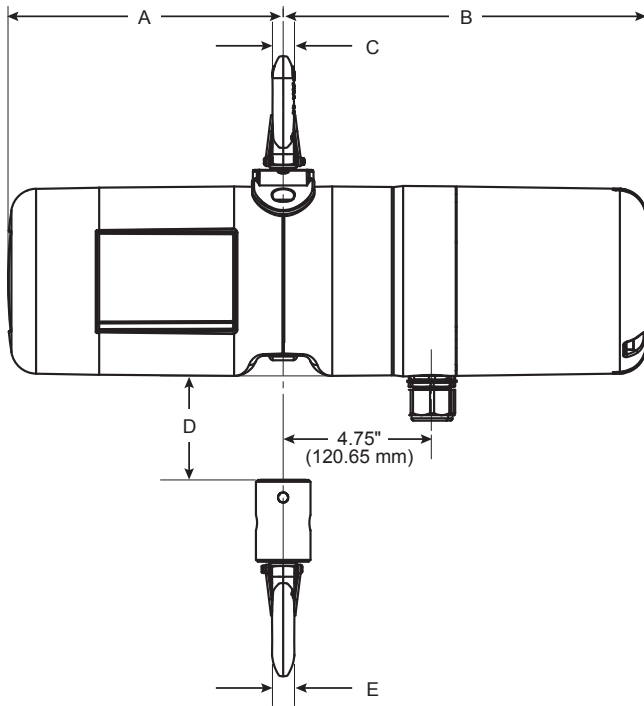

LARGE FRAME (MODELS J, L, R, RT)

For hoists with latch-type upper and lower hooks

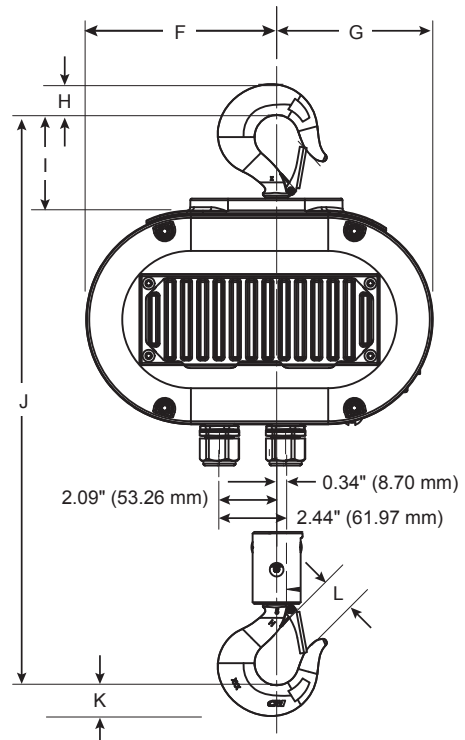
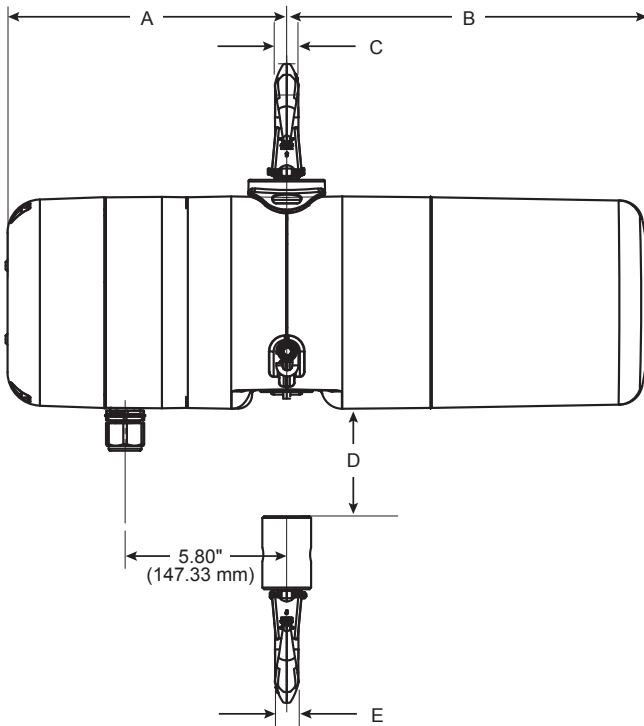

Note: When equipped with Intelli-Connect, a small box will be mounted to the hoist. This will not impact the overall height, width or length of the unit.

For a full list of dimensions (including for hoists configured with bullard hooks, Latchlok hooks, or trolleys), see CM Lodestar VS Dimension Drawing Book.



WWW.COLUMBUSMCKINNON.COM/CM

USA p: 800.888.0985
p: 716.689.5400
f: 716.689.5644
CAN p: 877.264.6478
f: 877.264.6477

SALES@CMWORKS.COM