

**CM**<sup>®</sup>

# **BANDIT**<sup>™</sup>

**RATCHET LEVER HOIST**



COLUMBUS MCKINNON CORPORATION

# CM<sup>®</sup>

# BANDIT<sup>™</sup>

## RATCHET LEVER HOIST

The CM<sup>®</sup> Bandit<sup>™</sup> is one of the most compact and durable ratchet lever hoists in the industry. Its lightweight and portable design, easy free-chaining feature and 360° rotating handle make it one of the most versatile hoists on the market today. Now available in 3/4, 1 1/2, 3 and 6 ton capacities for all of your pulling and lifting needs.

### BENEFITS & FEATURES

#### CAPACITIES & LIFT

Capacities of 3/4, 1 1/2, 3 & 6 tons.  
Metric Rated.  
Standard lifts up to 20 feet.  
Longer lifts are available.

#### COMPACT & PORTABLE DESIGN

Rugged yet lightweight design and construction allow the Bandit to be easily transported and used in even the most confined spaces.

#### CM<sup>®</sup> SMART ID<sup>™</sup> RFID TECHNOLOGY

Standard on all U.S. Bandit units.

#### EASY FREE-CHAINING

Allows for quick take up and positioning of slack chain. Designed not to accidentally free chain while under load.

#### 360° ROTATING HANDLE

Full rotation of handle allows for versatile rigging options when working in tight spaces.

#### LOW-EFFORT, COMFORT-FIT HANDLE

Double reduction gearing provides easy operation with minimal handle effort. Screwed-on comfortable rubber grip for a secure hold in all environments.

#### LOAD SECURITY & EASY INSPECTION

Upper and lower hooks feature standard cast safety latches that provide positive and secure load engagement. Hooks are bolted on for easy removal and inspection.

#### MEETS ASME B30.21

#### POSITIVE LOAD CONTROL

Enclosed Weston-type load brake stays clean and dry for positive load positioning.

#### EASY TO POSITION & ATTACH

Upper and lower hooks feature extra-wide throat openings to allow for easier attachment to pick points. Hooks swivel 360° for faster positioning.

#### BUILT TO LAST

Impact-resistant stamped steel housing withstands repeated rigorous use.

#### CORROSION RESISTANT

Standard powder coat finish on housing and zinc plating on major components for extra protection against corrosion in harsh environments.

#### 100% LOAD TESTED ZINC PLATED CHAIN

Protects against corrosion.

#### EASY IDENTIFICATION

Each unit has a unique serial number for easy and accurate identification.

#### OPTIONAL SHIPYARD HOOKS

Available on 1 1/2 & 3 ton units.

#### OPTIONAL INTERNAL LOAD LIMITER

Allows the handle to rotate freely, preventing the lifting of an overload sufficient to damage the hoist.

#### BANDITS SHIP IN 3 DAYS - GUARANTEED

3/4 & 1 1/2 ton units are eligible for our In-Stock Guarantee.



#### FAST & EASY PARTS ACCESS

Genuine CM Bandit parts are available in Total Repair Kits and convenient bulk packaging.



**LIFETIME  
WARRANTY™**



# WORK SMART. WORK SAFE.

## BE CONFIDENT WITH THE WORLD'S FIRST HMI-CERTIFIED RATCHET LEVER HOIST

Columbus McKinnon designed the CM Bandit to be the best lever hoist on the market. As a result, the Bandit has become the world's first HMI-Certified ratchet lever hoist, meeting strict nationally recognized industry standards. This certification supports our commitment to safety, service and aftermarket support. It instills customer confidence in the quality and value of the CM Bandit, which is also backed by our industry-leading lifetime warranty.



### WHAT IS THE HOIST MANUFACTURERS INSTITUTE (HMI)?

HMI is recognized as the authority and leading advocate for the safe and proper operation of hoisting equipment and related products. HMI members are industry-leading suppliers of material handling equipment, including the manufacturing and distribution of manual and powered hoists and trolleys.

### WHAT DOES HMI-CERTIFIED MEAN?

The purpose of HMI certification is to instill consumer confidence that the product and its manufacturer have met strict HMI requirements, which include that the manufacturer:

- Be a manufacturer of industrial hoisting equipment
- Have its product meet one or more requirements as stated by HMI
- Have a qualified, U.S.-registered professional engineer verify, sign and seal that the product meets the requirements
- Must provide a Declaration of Conformity for Technical, Service and Support

## DEMAND GENUINE PARTS

When you choose Parts Star™ by Columbus McKinnon, you'll be purchasing genuine Columbus McKinnon parts designed to fit the Bandit hoist's exact specifications; maintaining warranty requirements and the integrity of the unit's superior design and safety features.

Get everything you need for a complete and professional repair with Parts Star Total Repair

Kits. Popular Bandit repair parts are also available in easy-to-order bulk packaging so the parts you need are always on hand.



## SIMPLIFY YOUR INVENTORY & INSPECTION MANAGEMENT PROCESSES

CM® Smart ID™ – the new radio frequency identification (RFID) technology from Columbus McKinnon – is available as an option on all CM Bandit units. CM Smart ID can help simplify your inventory and inspection management processes.

CM Smart ID RFID chip is associated with product information that is uploaded and stored on the CM Smart ID Cloud. This free information, which includes the Chip ID number, CM product code, product description and capacity, can be instantly accessed by anyone in your company, anywhere, at any time.

CM Smart ID allows operators, safety managers and plant supervisors to share important safety information and inspection logs about a specific unit, as well as easily record and track equipment inventory.



## PROTECT AGAINST UNSAFE LIFTING CONDITIONS

All Canadian CM Bandit units feature the Tri-Point Hook Inspection™ system to help protect the operator against unsafe lifting conditions. Bandit load hooks come with 3 distinct raised points that the operator can use to measure the hook to detect any indication of overload or deformation.



## SPECIFICATIONS & DIMENSIONS

Model Number	Capacity Metric Rated Ton (kg)	Standard Lift FT (m)	Lever Pull to Lift Rated Load LBF (kg)	Net Weight LB (kg)	Dimensions Inches (mm)										
					A	B	C	D	E	F	G	H	J	K	L
BAN07505	3/4 (750)	5 (1.52)	45 (20.41)	13.6 (6.17)	12.80 (325.12)	0.94 (23.88)	1.13 (28.70)	0.69 (17.53)	9.63 (244.60)	4.88 (123.95)	2.19 (55.63)	3.31 (84.07)	6.06 (153.92)	2.11 (53.59)	3.95 (100.33)
BAN07510		10 (3.05)		15.7 (7.12)											
BAN07515		15 (4.57)		18 (8.16)											
BAN07520		20 (6.1)		20.1 (9.12)											
BAN15005	1-1/2 (1500)	5 (1.52)	64 (29.03)	20.7 (9.39)	14.20 (360.68)	1.13 (28.70)	1.25 (31.75)	0.81 (20.57)	10.25 (260.35)	5.63 (143.00)	2.38 (60.45)	3.56 (90.42)	6.75 (171.45)	2.69 (68.33)	4.13 (104.90)
BAN15010		10 (3.05)		24.3 (11.02)											
BAN15015		15 (4.57)		27.9 (12.65)											
BAN15020		20 (6.1)		31.5 (14.29)											
BAN30005	3 (3000)	5 (1.52)	73 (33.11)	38.3 (17.37)	17.50 (444.5)	1.69 (42.93)	1.56 (39.62)	1.25 (31.75)	16.37 (415.8)	7.52 (191.01)	3.38 (85.85)	4.65 (118.11)	7.84 (199.14)	3.29 (83.57)	4.56 (115.82)
BAN30010		10 (3.05)		45.7 (20.73)											
BAN30015		15 (4.57)		53 (24.04)											
BAN30020		20 (6.1)		60.4 (27.4)											
BAN60005	6 (6000)	5 (1.52)	93 (42.18)	63.2 (28.67)	22.00 (558.8)	1.81 (45.97)	2.19 (55.63)	1.50 (38.1)	16.37 (415.8)	9.47 (240.54)	3.38 (85.85)	6.05 (153.67)	7.84 (199.14)	3.29 (83.57)	4.56 (115.82)
BAN60010		10 (3.05)		77.9 (35.33)											
BAN60015		15 (4.57)		92.6 (42.00)											
BAN60020		20 (6.1)		107.3 (48.7)											

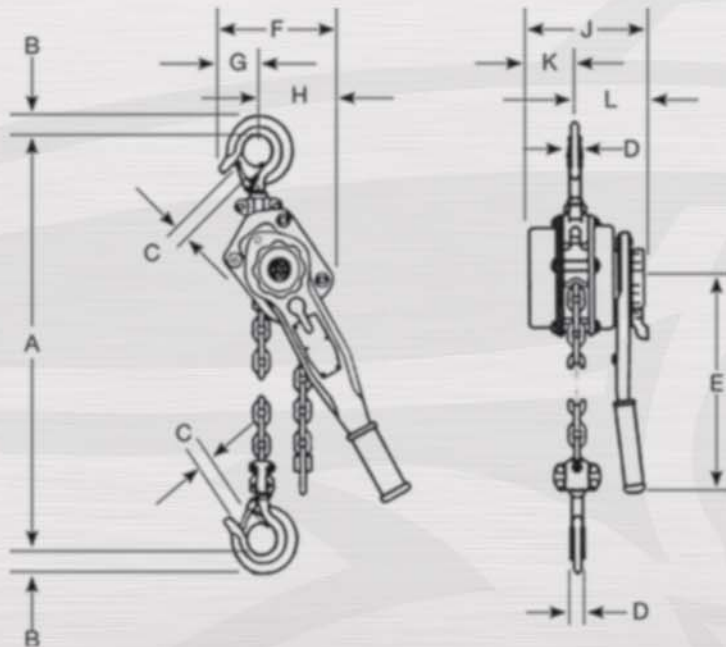

# THE ANATOMY OF THE BANDIT™

The CM Bandit was designed and built with one purpose – to be the best ratchet lever hoist in the global marketplace.

Manufactured by Columbus McKinnon at our CMCO China facility, every component on the CM Bandit is engineered for superior design and efficiency. Working together, these components provide best-in-class performance and exceptional value for any application.

## BOLT-ON SWIVEL HOOKS

Bolt-on hooks with nylon lock nuts allow the operator to quickly disassemble the hook block for full inspection and easy repairs. Helps users comply with inspection requirements stated in ASME B30.21 and B30.10.

Hooks rotate 360° for faster positioning and attachment to pick points.

## CAST SAFETY LATCHES

Upper and lower hooks feature cast safety latches that provide positive and secure load engagement.

## WIDE HOOK THROAT OPENINGS

Upper and lower hooks feature extra-wide throat openings to allow for easier attachment to loads and larger pick points.



## WESTON-TYPE BRAKE

Enclosed brake stays clean and dry for positive load positioning.

## FUSED BRAKE ASSEMBLY

Fused brake and ratchet design provides exceptional performance, durability and long life. Fused brake disks are also less susceptible to cracking and catastrophic failure. Design allows for thinner friction liners, less moving parts and fewer parts to keep in stock.

## 3-YEAR BRAKE WARRANTY

If the brake discs on the Bandit wear out within three years from the date of purchase, CMCO will replace the ratchet disc assembly free of charge.



## BEARINGS

Provide smooth operation, lower handle effort and serve as a barrier to contamination. Plated side plate resists corrosion.



## PAWLS & PLATE

Heavy-duty double pawls ensure secure load engagement with ratchet brake assembly to provide better load control. Plated side plate resists corrosion.



## HAND WHEEL

Use hand wheel to put the hoist in free chaining mode, which allows for quick take up and positioning of slack chain. Designed not to accidentally free chain while under load. Optional Load Limiter features black hand wheel.

### 360° ROTATING HANDLE

Full rotation of handle allows for versatile rigging options when working in confined spaces. Hoist features double-reduction gearing for easy operation with minimal handle effort.

### UNIQUE SERIAL NUMBER

Each unit has a unique serial number for easy and accurate identification.

### SECURE COMFORT GRIP

Screwed-on comfortable rubber grip ensures a secure hold in all environments.

### OPTIONAL INTERNAL LOAD LIMITER

Allows the handle to rotate freely, preventing the lifting of an overload sufficient to damage the hoist.



### POCKET WHEEL

2-part design for easy inspection and low-cost replacement.

### PINION

Made of tough and durable grade three carburized steel.



### CHAIN END STOP

Chain end stop design prevents it from entering the lift wheel and jamming the hoist. Made of forged alloy steel for durability.

### 100% LOAD TESTED, ZINC PLATED CHAIN

Protects against corrosion.



### ZINC-PLATED COMPONENTS

Zinc plating provides protection against corrosion when working in harsh environments. (Chain Guide components shown)



### HOUSING

Impact-resistant, stamped-steel housing withstands repeated rigorous use. Features recognizable orange powder-coat finish for extra protection against corrosion.



### NYLON LOCK NUTS

Nylon lock nuts are used to hold the hoist body together. Lock nuts can be securely torqued and are less likely to loosen in the field.



## THE POWER OF INTELLIGENT LIFTING

Columbus McKinnon is one of the most respected and well-known names in the material handling industry. We combine two different yet complimentary areas of expertise – rigging products and hoists – to develop complete floor-to-ceiling lifting systems for even the most unique material handling applications.

Columbus McKinnon designs and manufactures a large portfolio of durable and reliable products for a variety of industries. Our portfolio includes powered and manual hoists, rigging products, below-the-hook attachments, cranes, enclosed track systems and specially engineered products.

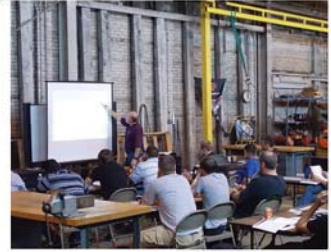

## KNOW HOW. KNOW WHY. BE SAFE. GET TRAINED.

Not only is Columbus McKinnon a leader in material handling products, we are also a global leader in providing expertise and training on the proper use and inspection of rigging and overhead lifting equipment. With a range of comprehensive programs and seminars conducted at venues throughout North America, including our hands-on training centers and private companies, our courses include:

- Hoist Maintenance
- Safe Hoisting
- Rigging Gear Inspection
- Crane & Hoist Inspection
- Load Securement
- Crane Operator Training
- Rigging

One of our newest programs, **CMCO University™**, is a three-day course designed to give attendees an intimate knowledge of our products, the information they'll need to select the right product for the application, and the tools to win in the marketplace.

Classes are available at our state-of-the-art, hands-on training centers, including the **Niagara Training Center** and the **Hoist & Rigging Training Center of Excellence in the Center for Occupational Health and Automobile Manufacturing (COHAM) lab at The Ohio State University**.

Rely on Columbus McKinnon for the products and expertise you need to keep your workforce productive and safe.



For more information:

Phone: 800.888.0985 • 716.689.5400

[www.cmworks.com](http://www.cmworks.com)

